

1107 MAIN

HAMILTON

EXCLUSIVE INCENTIVES

EXTENDED DEPOSIT STRUCTURE

\$10,000 on Signing

Balance to 5% in 15 days

5% in 180 days

5% on February 1, 2025

5% three months prior to Occupancy

Payable to Levy Zavet PC in Trust

CAPPED DEVELOPMENT CHARGES

1 Bedroom & Den and Smaller at \$12,000

2 Bedroom and Larger at \$15,000

SMART HOME TECH PACKAGE

FURNISHED SUITE PACKAGES,

2 YEAR LEASE GUARANTEE

AND RENTAL MANAGEMENT

or

CREDIT ON CLOSING

\$10,000 for 1 Bedroom & Den Suites and Smaller

\$15,000 for 2 Bedroom Suites and Larger

\$500 ASSIGNMENT FEE + \$1,250 LEGAL FEE

(Reduced from \$5,000 + \$1,250 Legal Fee)



1107 MAIN

HAMILTON



PRICE LIST

Model	Suite Type	View	Bathroom	Interior Size	Exterior Size	Total Size	Starting Price*	Lease Amount
B441	1 Bedroom	East (C)	1	441	81	522	\$557,990	\$2,450
C470	1 Bedroom + Den	Southwest	1	470	0	470	\$557,990	\$2,600
C507	1 Bedroom + Den	North	1	507	34	541	\$589,990	\$2,650
C518	1 Bedroom + Den	South (C)	1	518	51	569	\$605,990	\$2,650
C500	1 Bedroom + Den	North	1	500	32	532	\$621,990	\$2,700
C548	1 Bedroom + Den	Southwest	1	548	131	679	\$623,990	\$2,700
D626	1 Bedroom + Den	South (C)	1.5	626	0	626	\$629,990	\$2,800
C527	1 Bedroom + Den	South	1	527	51	578	\$632,990	\$2,700
C555	1 Bedroom + Den	East	1	555	51	606	\$633,990	\$2,700
D599b	1 Bedroom + Den	North	2	599	32	631	\$645,990	\$2,800
E613a	2 Bedroom (I)	North	2	613	25	637	\$681,990	\$3,200
D574	1 Bedroom + Den	Northwest	2	574	84	658	\$684,990	\$2,900
E599	2 Bedroom (I)	West	2	599	113	650	\$690,990	\$3,200
E707	2 Bedroom (I)	West	2	707	42	749	\$695,990	\$3,200
E718	2 Bedroom	West (C)	2	718	52	770	\$708,990	\$3,300
E669a	2 Bedroom	Northwest	2	669	0	669	\$714,990	\$3,300
E643	2 Bedroom	Southwest	2	643	160	803	\$744,990	\$3,400
E789	2 Bedroom	North	2	792	53	845	\$769,990	\$3,800
E780	2 Bedroom	Northeast	2	780	51	831	\$778,990	\$3,800
E767	2 Bedroom	Southeast (C)	2	767	51	818	\$774,990	\$3,800

<p><u>Extended Deposit Structure</u> \$10,000 on Signing Balance to 5% in 15 days 5% in 180 days 5% on February 1, 2025 5% three months prior to Occupancy 5% (Payable to Levy Zavet PC in Trust)</p>	<p><u>Maintenance Fees</u> \$0.69/sqft on all suites</p> <p>Includes common elements, 16hr concierge M-F, 24hr concierge Sat-Sun, heating/cooling, gas, water, bulk internet. Excludes hydro.</p> <p>Parking Maintenance Fee: \$135.00/month Below Grade Locker Maintenance Fee: \$25.00/month Above Grade Locker Maintenance Fee: \$35.00/month Parking/Locker Combination Maintenance Fee: \$165.00/month Bicycle Storage Maintenance Fee: \$8.00/month</p>	<p><u>Standard Parking</u> \$65,000</p> <p><u>15 sqft Below Grade Locker</u> \$4,000</p> <p><u>45 sqft Above Grade Locker</u> \$6,000</p> <p><u>Parking/Locker Combination</u> \$75,000</p> <p><u>Bicycle Storage</u> \$500.00</p> <p><u>Occupancy Date</u> May, 2027</p> <p><u>Property Taxes</u> See City Posted Rates</p>
---	--	---

*Floor premiums range from \$1,000-\$20,000 **Availability, features, promotions, and prices are subject to change without notice. Some conditions apply. Please consult an RDS Sales Representative for details.



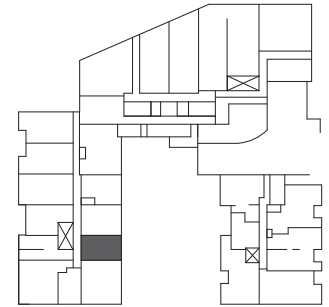
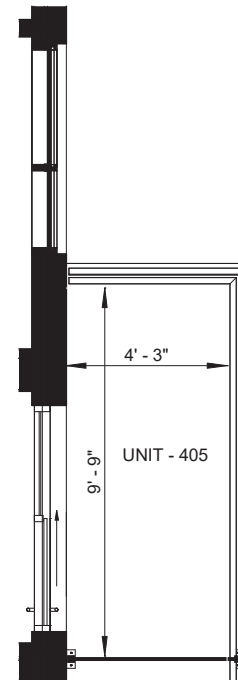
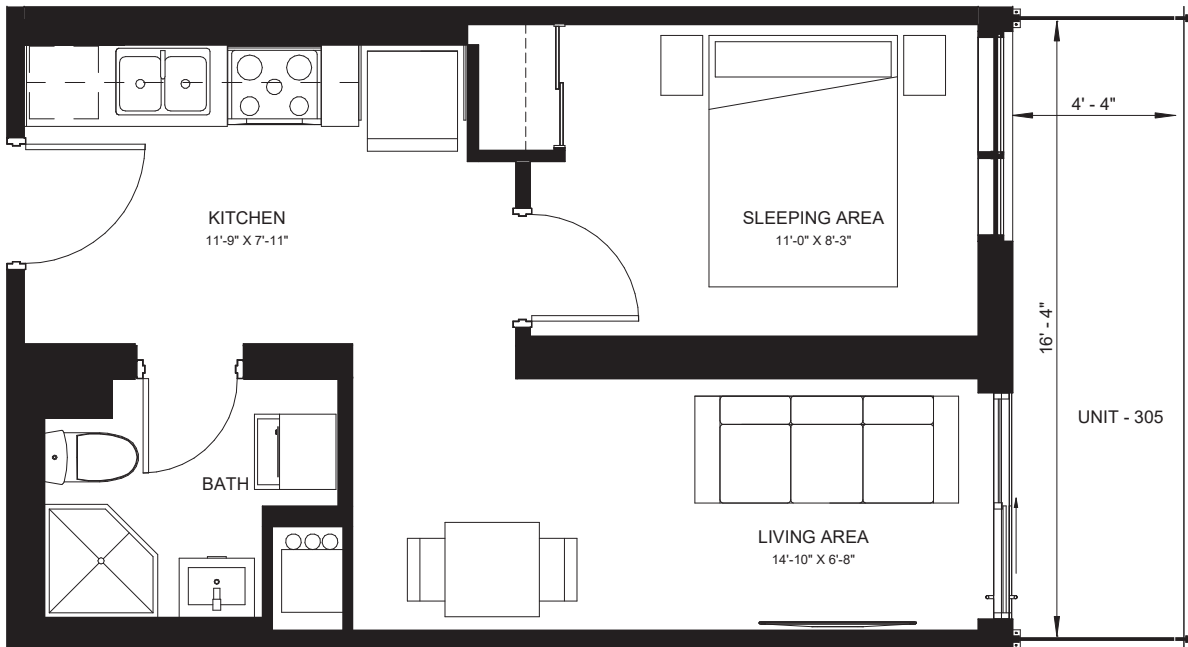

LEVEL 2

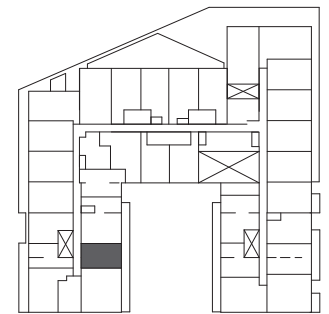

LEVEL 3

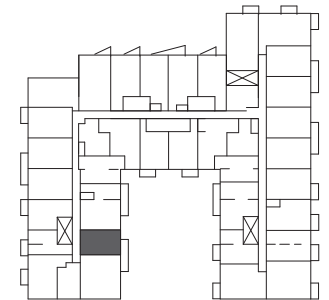

LEVEL 4

**1107
MAIN**
HAMILTON

1 BED

B441

SUITE: 441 SQ.FT. TERRACE: 81 SQ.FT. TOTAL: 522 SQ.FT. | UNITS: #203, 305

SUITE: 440 SQ.FT. BALCONY: 51 SQ.FT. TOTAL: 491 SQ.FT. | UNIT: #405

IN8

Illustrations are concept only. Plans and specifications are subject to change without notice. Actual floor space may vary from stated floor area. See sales representative for more information. E. & O. E.

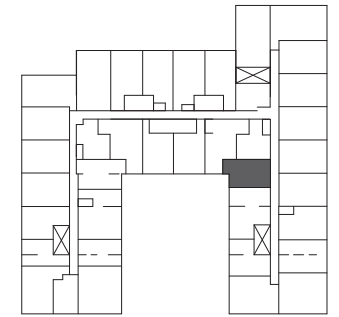
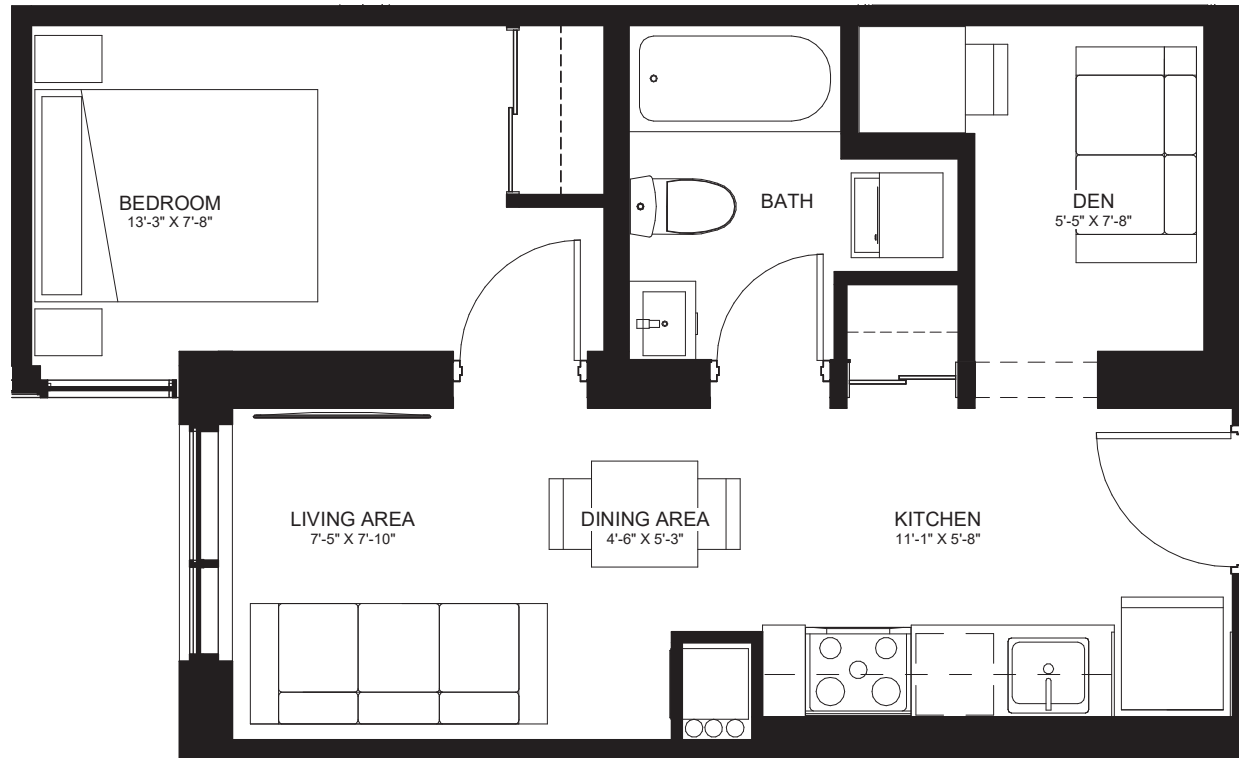

LEVEL 4

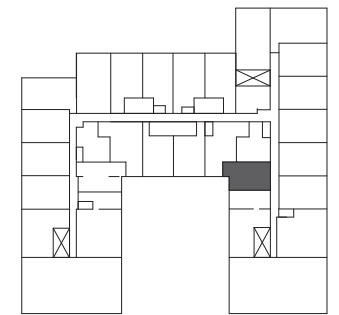

LEVEL 5

**1107
MAIN**
HAMILTON

1 BED + DEN

C470

SUITE: 470 SQ.FT. | UNITS: #433, 524

IN8

Illustrations are concept only. Plans and specifications are subject to change without notice. Actual floor space may vary from stated floor area. See sales representative for more information. E. & O. E.

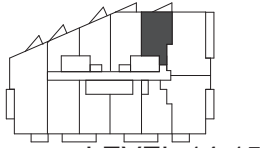
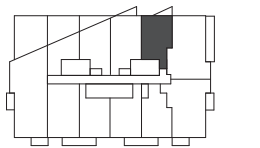
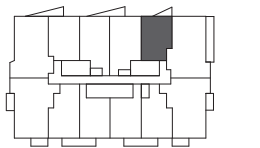
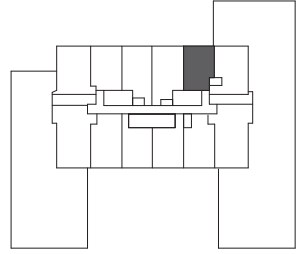
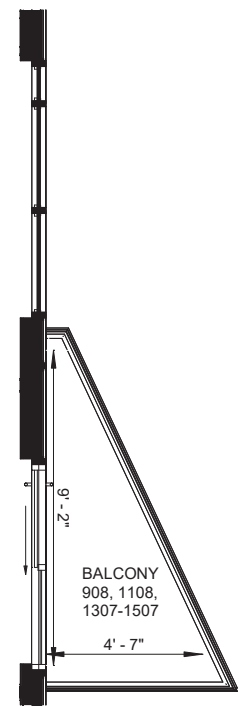
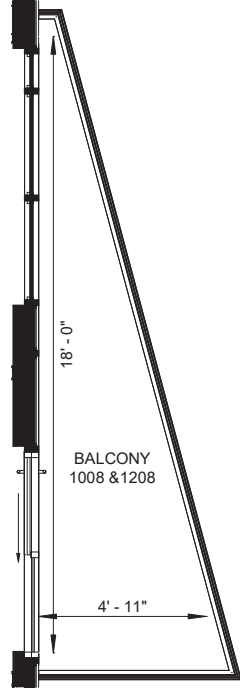
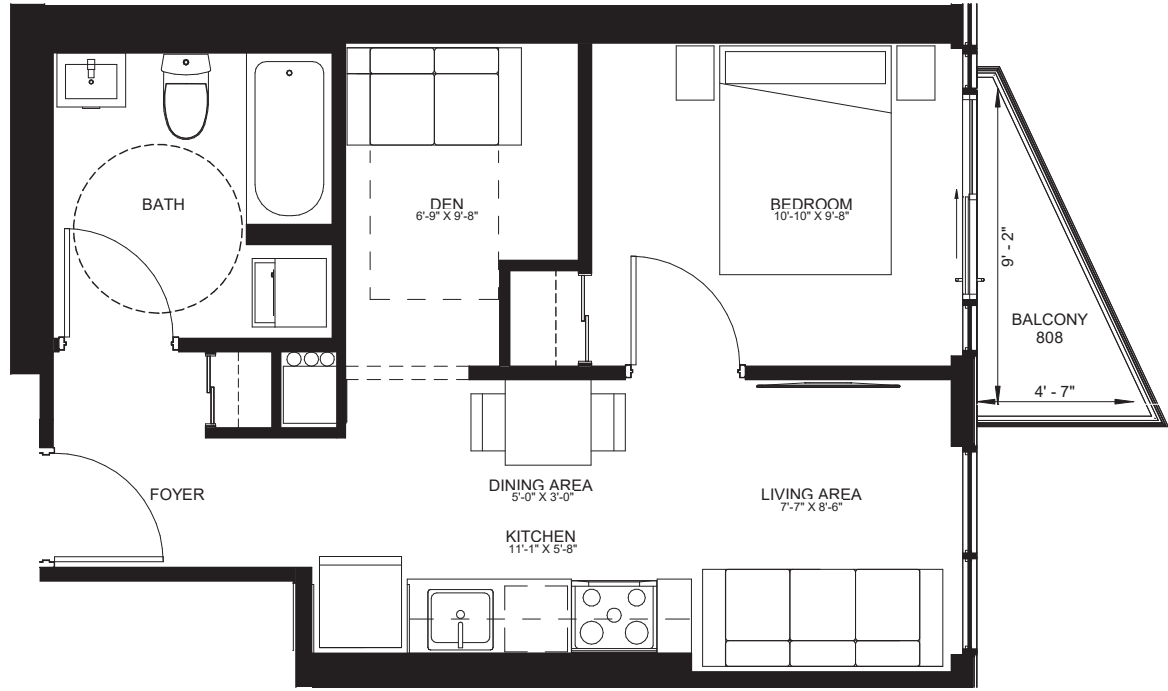

1 BED + DEN

C500

SUITE: 500 SQ.FT.

BALCONY: 32 SQ.FT.

TOTAL: 532 SQ.FT. | UNIT: #808

SUITE: 500 SQ.FT.

BALCONY: 64 SQ.FT.

TOTAL: 564 SQ.FT. | UNITS: #1008, 1208

SUITE: 501 SQ.FT.

BALCONY: 34 SQ.FT.

TOTAL: 535 SQ.FT. | UNITS: #908, 1108, 1307-1507

**1107
MAIN**
HAMILTON

IN8

Illustrations are concept only. Plans and specifications are subject to change without notice. Actual floor space may vary from stated floor area. See sales representative for more information. E. & O. E.

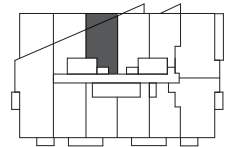
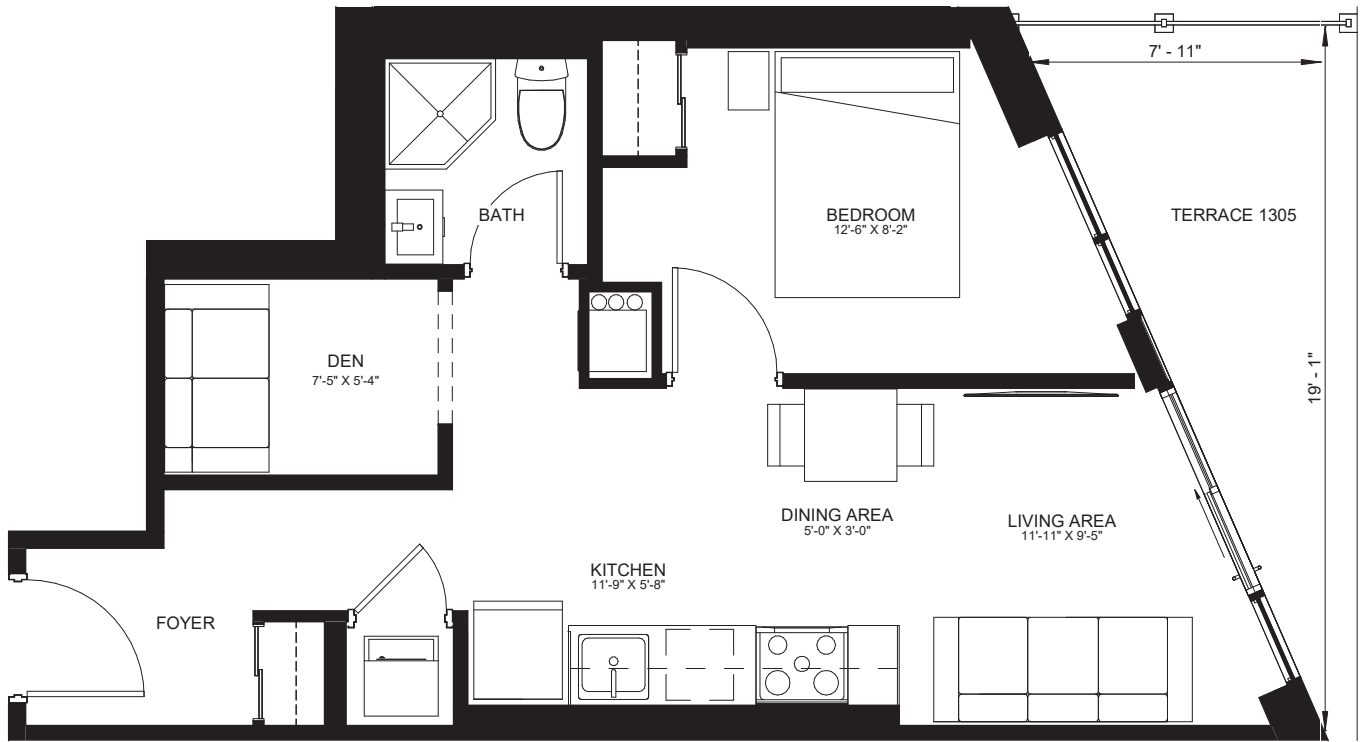

LEVEL 13

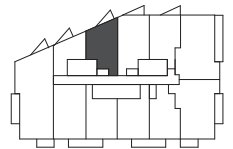

LEVEL 14-15

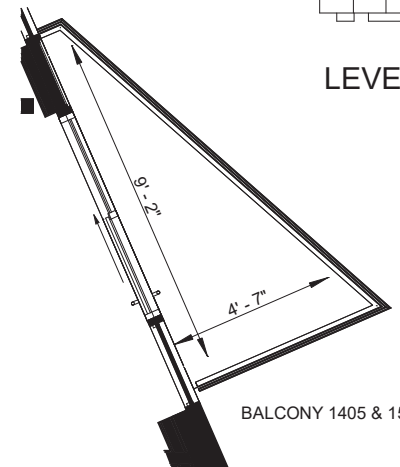

BALCONY 1405 & 1505

**1107
MAIN**
HAMILTON

1 BED + DEN

C507

SUITE: 507 SQ.FT. TERRACE: 115 SQ.FT. TOTAL: 622 SQ.FT. | UNIT: #1305

SUITE: 507 SQ.FT. BALCONY: 34 SQ.FT. TOTAL: 541 SQ.FT. | UNITS: #1405-1505

IN8

Illustrations are concept only. Plans and specifications are subject to change without notice. Actual floor space may vary from stated floor area. See sales representative for more information. E. & O. E.

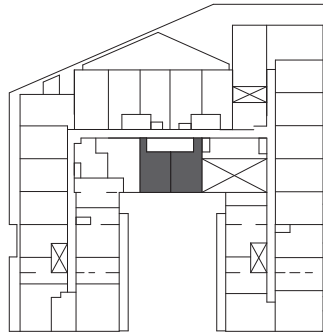
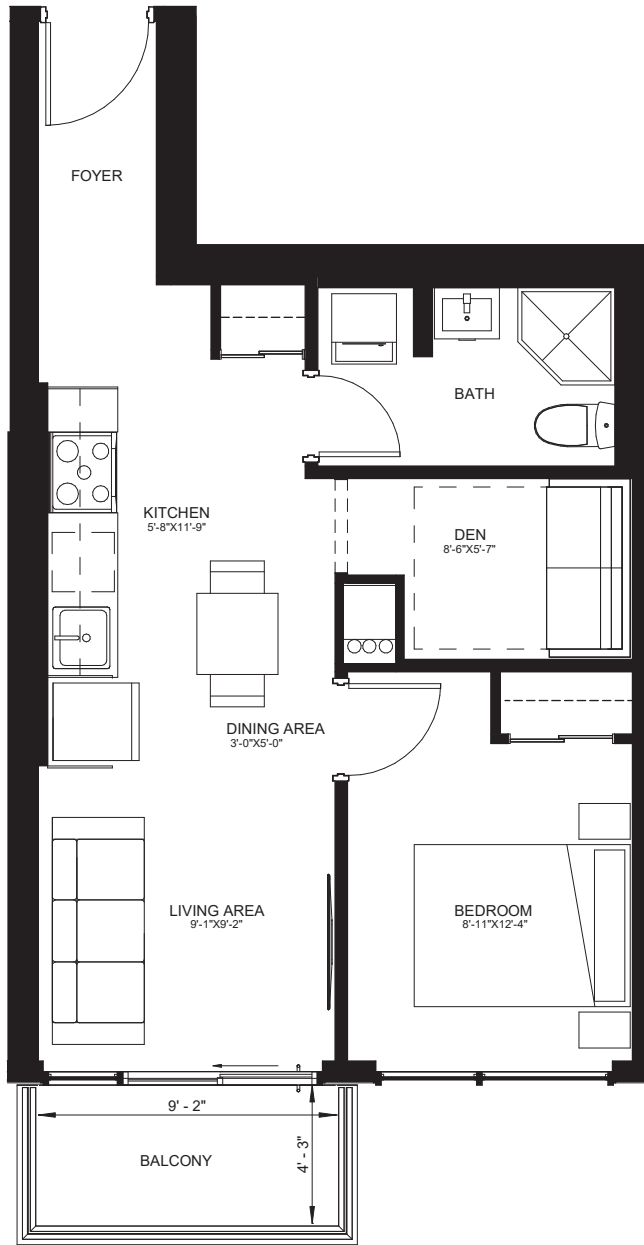

LEVEL 3

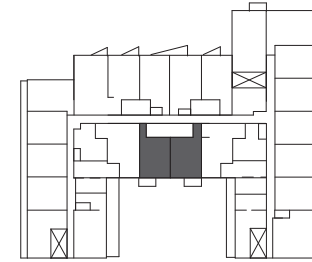

LEVEL 6

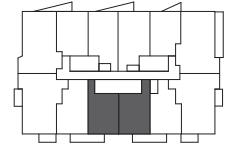

LEVEL 9-12

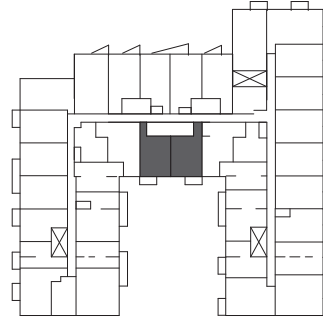

LEVEL 4

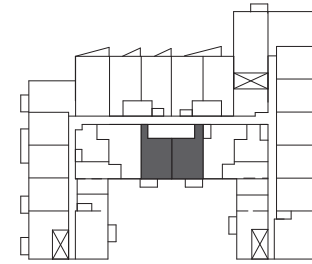

LEVEL 7

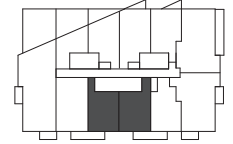

LEVEL 13

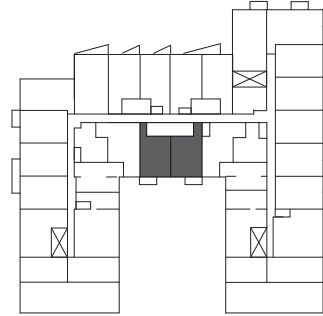

LEVEL 5

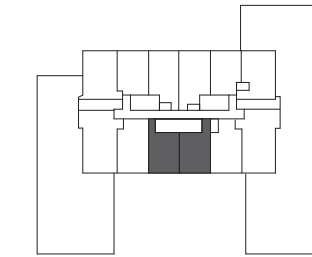

LEVEL 8

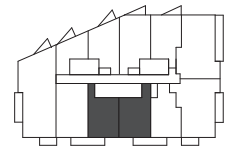

LEVEL 14-15

1 BED + DEN

C518

SUITE: 518 SQ.FT.
 SUITE: 521 SQ.FT.
 SUITE: 522 SQ.FT.
 SUITE: 524 SQ.FT.

BALCONY: 51 SQ.FT.
 BALCONY: 51 SQ.FT.
 BALCONY: 51 SQ.FT.
 BALCONY: 51 SQ.FT.

TOTAL: 569 SQ.FT. |
 TOTAL: 572 SQ.FT. |
 TOTAL: 573 SQ.FT. |
 TOTAL: 574 SQ.FT. |

UNITS: #301-1501
 UNITS: #912-1212
 UNITS: #812, 1311-1511
 UNITS: #333, 435, 526-726

1107
MAIN
 HAMILTON

IN8

Illustrations are concept only. Plans and specifications are subject to change without notice. Actual floor space may vary from stated floor area. See sales representative for more information. E. & O. E.

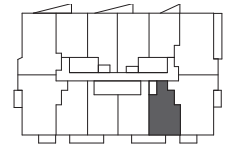

LEVEL 9-12

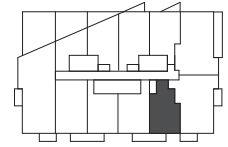

LEVEL 13

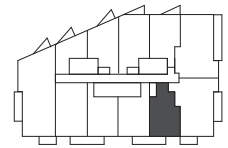

LEVEL 14-15

**1107
MAIN**
HAMILTON

1 BED + DEN

C527

SUITE: 527 SQ.FT.

BALCONY: 51 SQ.FT.

TOTAL: 578 SQ.FT. |

UNITS: #911-1211, 1310-1510

IN8

Illustrations are concept only. Plans and specifications are subject to change without notice. Actual floor space may vary from stated floor area. See sales representative for more information. E. & O. E.

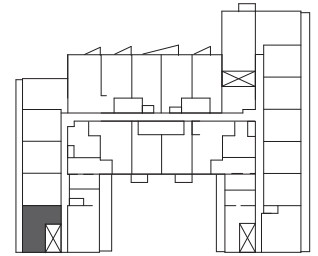
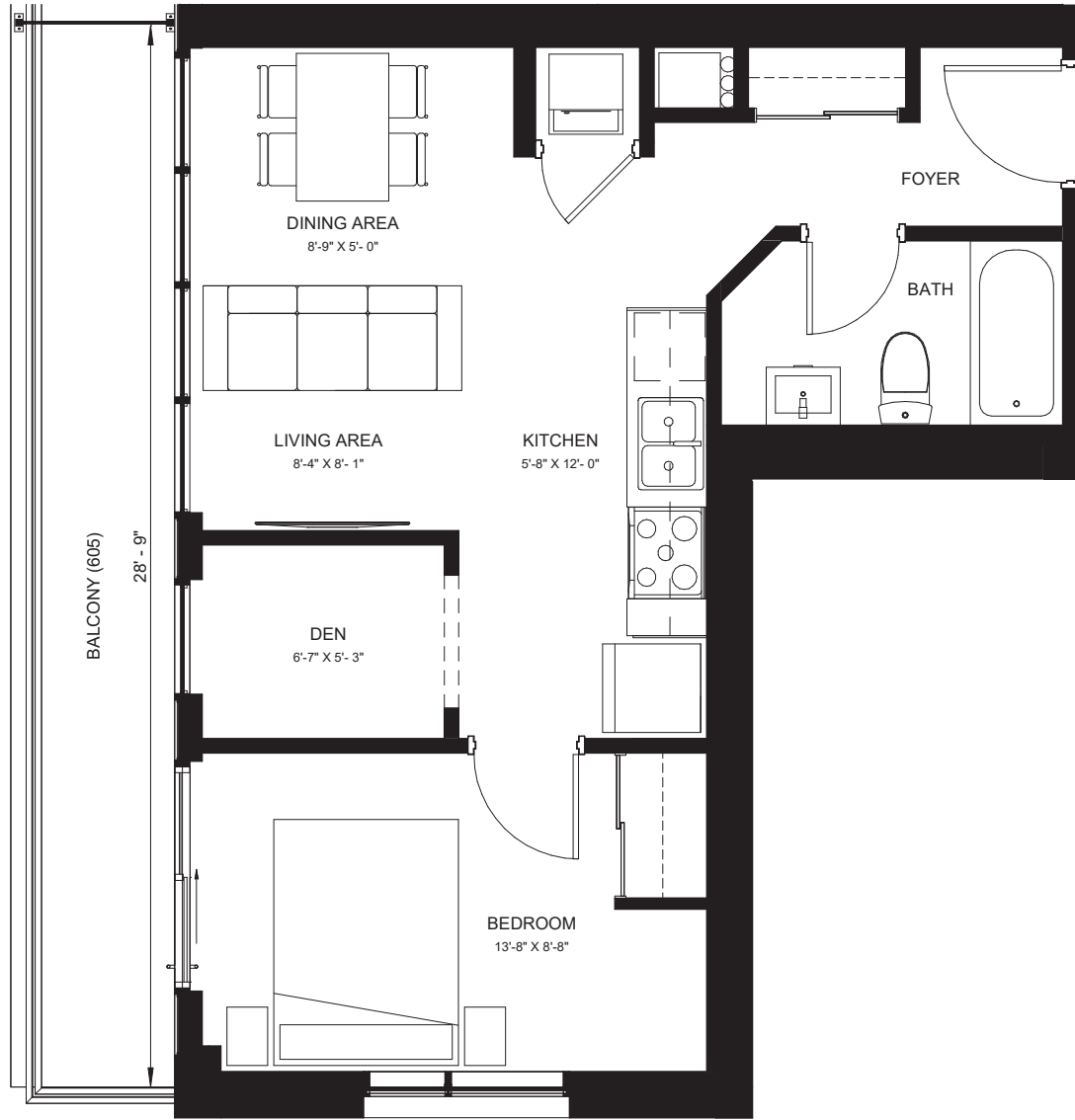

LEVEL 6

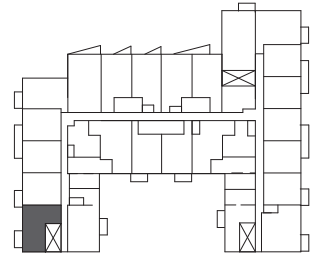

LEVEL 7

**1107
MAIN**
HAMILTON

1 BED + DEN

C548

SUITE: 548 SQ.FT. | BALCONY: 131 SQ.FT. | TOTAL: 679 SQ.FT. | UNIT: #605

SUITE: 548 SQ.FT. | BALCONY: 51 SQ.FT. | TOTAL: 599 SQ.FT. | UNIT: #705

IN8

Illustrations are concept only. Plans and specifications are subject to change without notice. Actual floor space may vary from stated floor area. See sales representative for more information. E. & O. E.

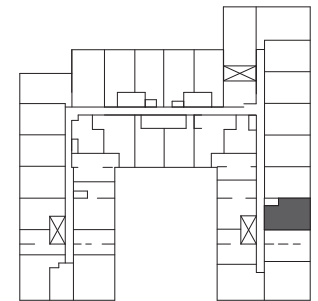
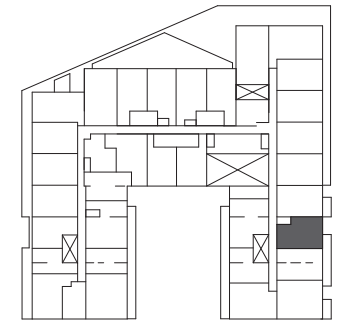
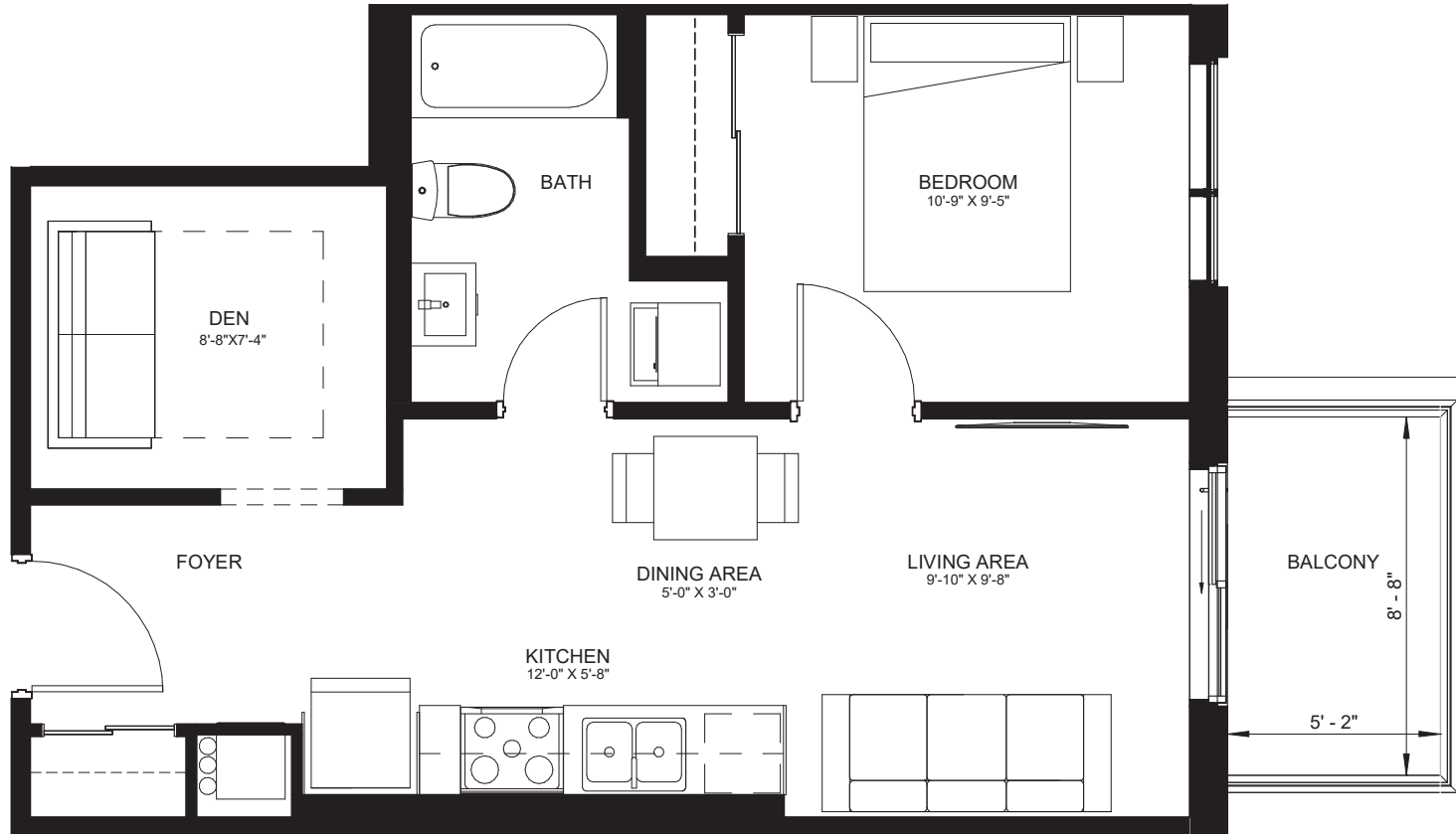

**1107
MAIN**
HAMILTON

1 BED + DEN

C555

SUITE: 555 SQ.FT. BALCONY: 51 SQ.FT. TOTAL: 606 SQ.FT. | UNITS: #327-427

IN8

Illustrations are concept only. Plans and specifications are subject to change without notice. Actual floor space may vary from stated floor area. See sales representative for more information. E. & O. E.

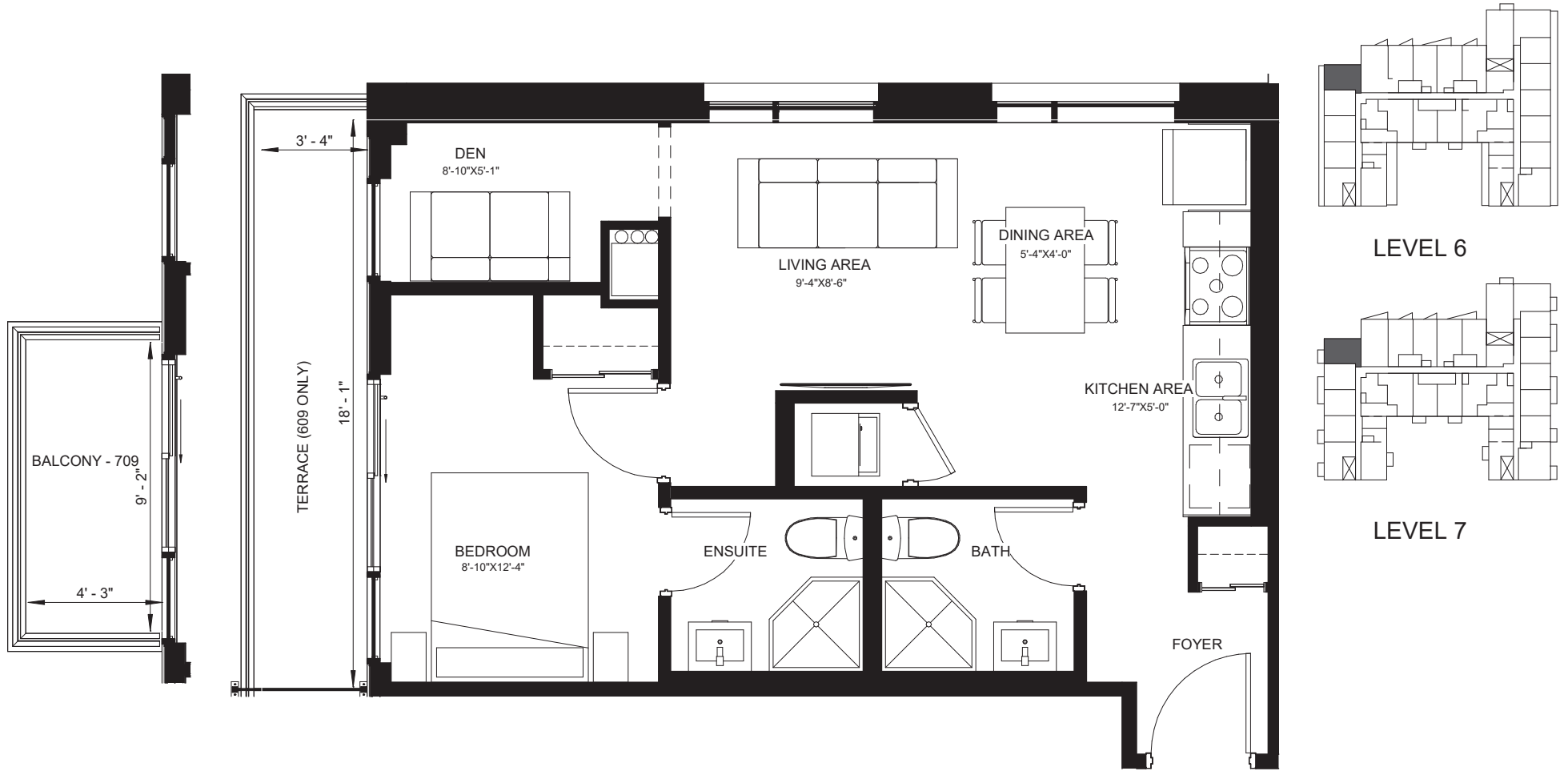

1 BED + DEN

D574

SUITE: 574 SQ.FT. TERRACE: 84 SQ.FT. TOTAL: 658 SQ.FT. | UNIT: #609

SUITE: 565 SQ.FT. BALCONY: 51 SQ.FT. TOTAL: 616 SQ.FT. | UNIT: #709

IN8

**1107
MAIN**
HAMILTON

Illustrations are concept only. Plans and specifications are subject to change without notice. Actual floor space may vary from stated floor area. See sales representative for more information. E. & O. E.



NORTH

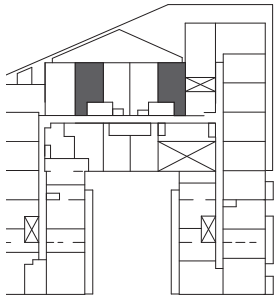

LEVEL 3

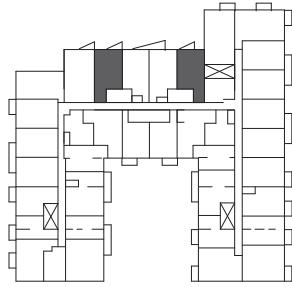

LEVEL 4

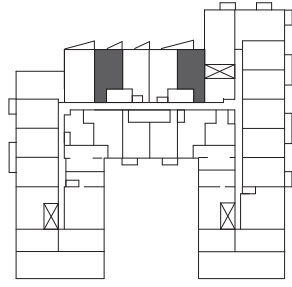

LEVEL 5

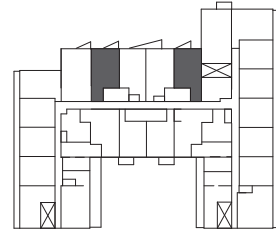

LEVEL 6

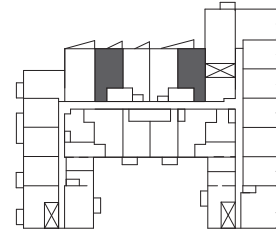

LEVEL 7

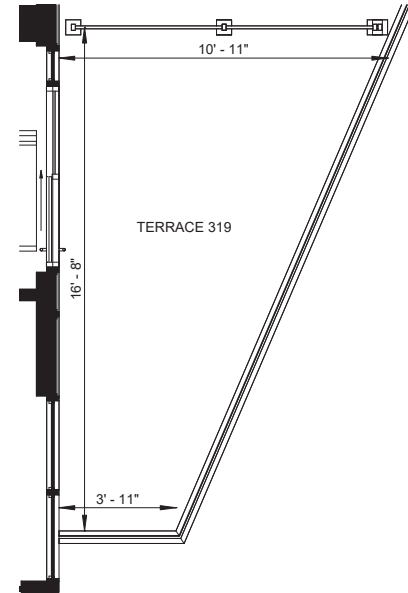

TERRACE 319

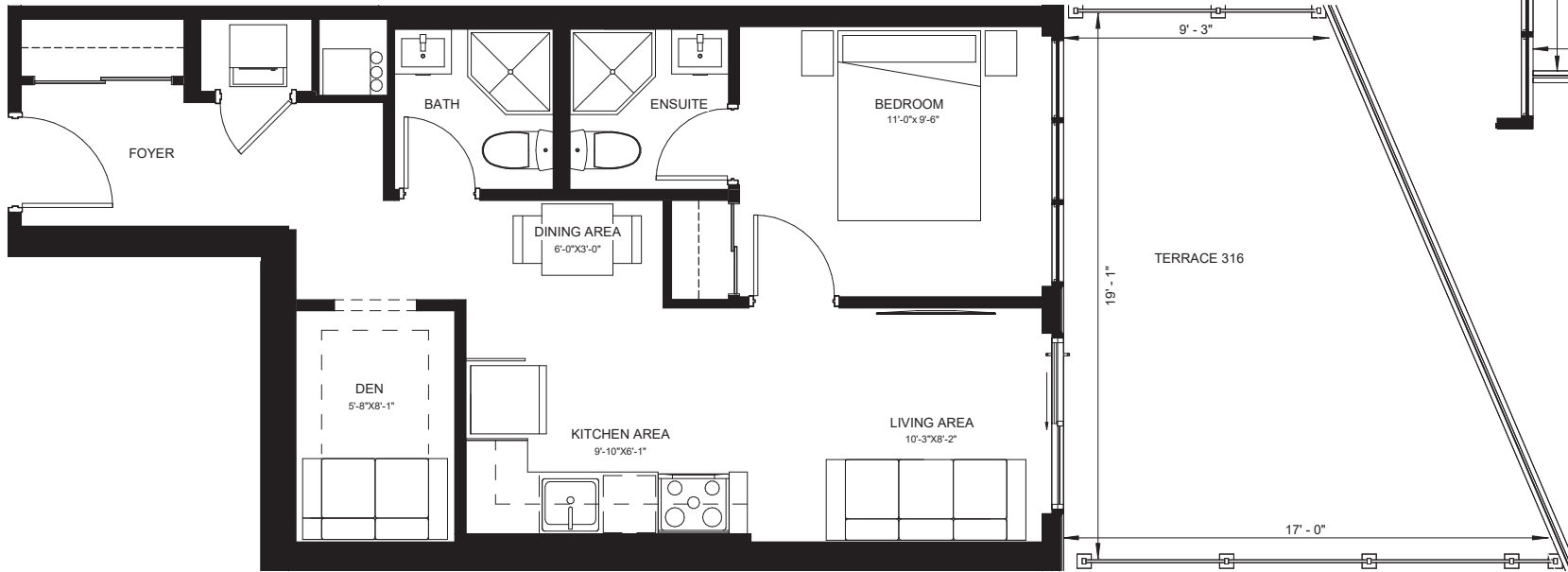

TERRACE 316

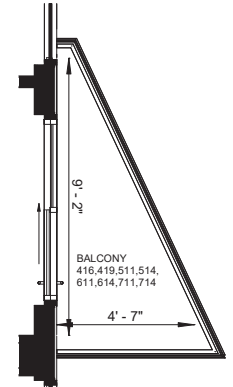

BALCONY
416, 419, 511, 514,
611, 614, 711, 714

1 BED + DEN

**1107
MAIN**
HAMILTON

D599b

SUITE: 599 SQ.FT.
SUITE: 598 SQ.FT.
SUITE: 599 SQ.FT.
SUITE: 598 SQ.FT.

TERRACE: 265 SQ.FT.
TERRACE: 133 SQ.FT.
BALCONY: 32 SQ.FT.
BALCONY: 32 SQ.FT.

TOTAL: 864 SQ.FT. | UNITS: #316
TOTAL: 731 SQ.FT. | UNITS: #319
TOTAL: 631 SQ.FT. | UNITS: #416, 511-711
TOTAL: 630 SQ.FT. | UNITS: #419, 514-714

Illustrations are concept only. Plans and specifications are subject to change without notice. Actual floor space may vary from stated floor area. See sales representative for more information. E. & O. E.

IN8

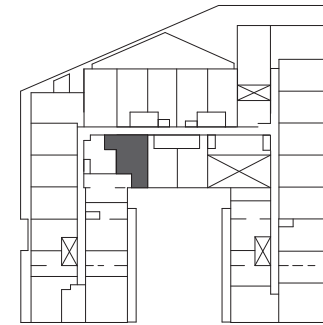
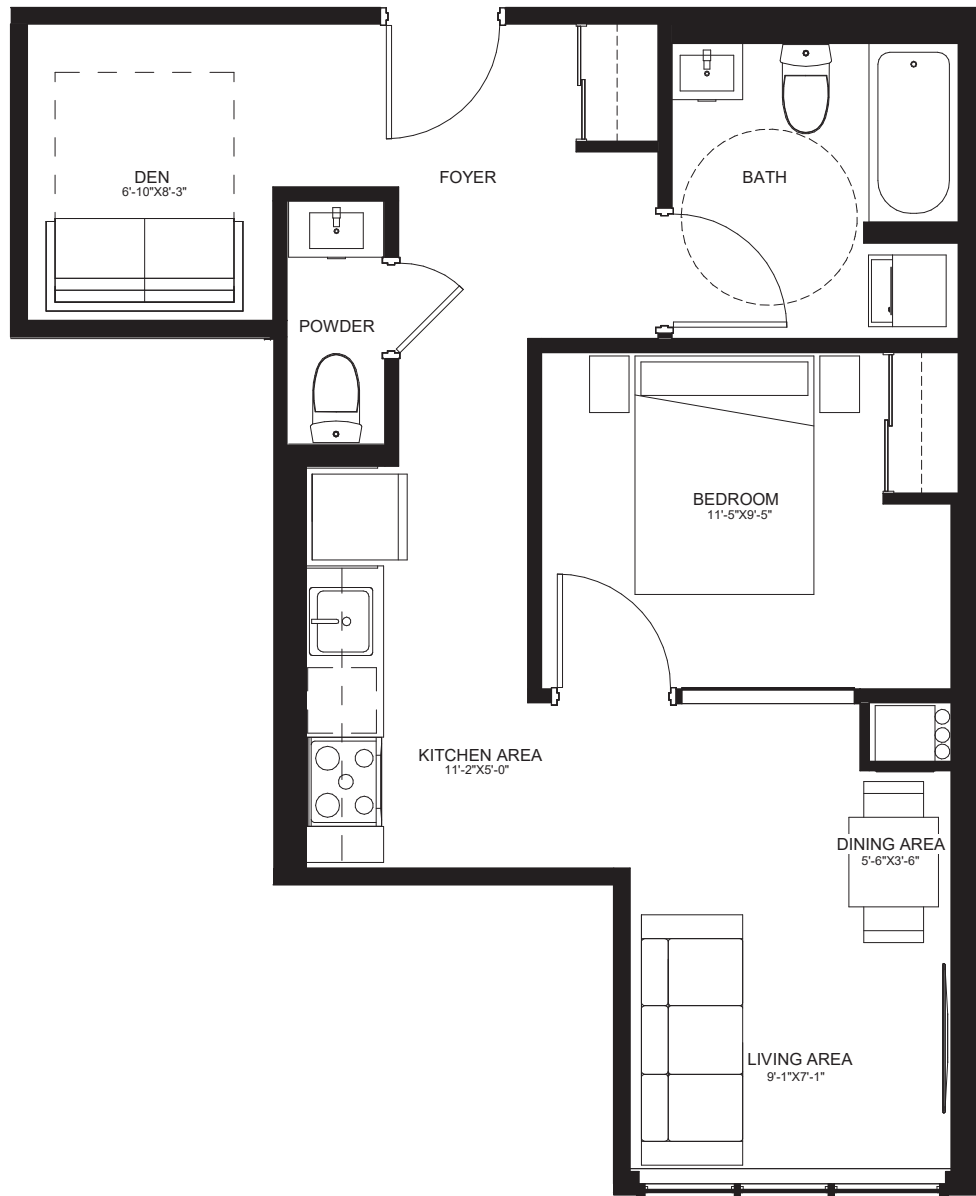

LEVEL 3

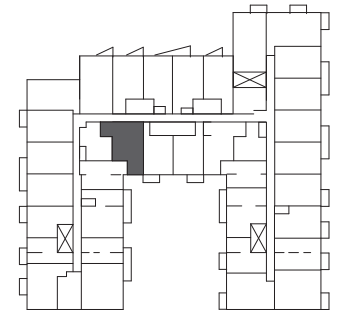

LEVEL 4

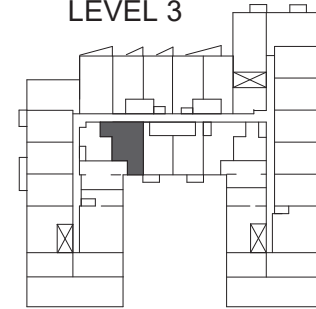

LEVEL 5

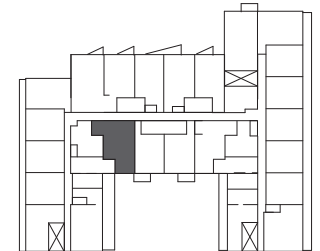

LEVEL 6

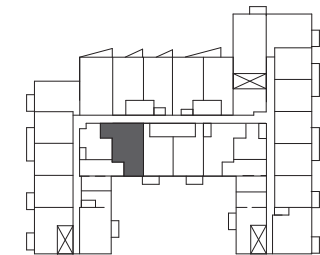

LEVEL 7

1 BED + DEN

**1107
MAIN**
HAMILTON

D626

SUITE: 626 SQ.FT. | UNITS: #302, 502, 702

SUITE: 627 SQ.FT. | UNITS: #402, 602

IN8

Illustrations are concept only. Plans and specifications are subject to change without notice. Actual floor space may vary from stated floor area. See sales representative for more information. E. & O. E.

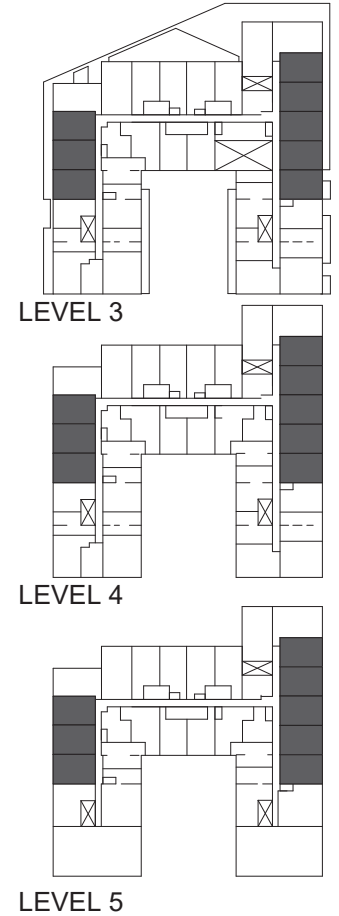
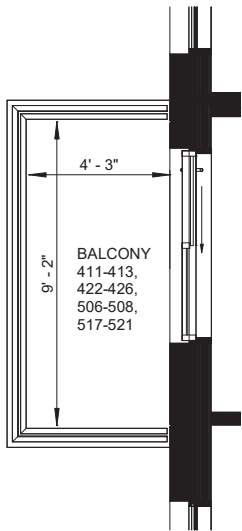

**1107
MAIN**
HAMILTON

2 BED

E599

SUITE: 599 SQ.FT.

TERRACE: 113 SQ.FT.

TOTAL: 712 SQ.FT.

UNITS: #311-313, 322-326

SUITE: 599 SQ.FT.

BALCONY: 51 SQ.FT.

TOTAL: 650 SQ.FT.

UNITS: #411-413, 422-426, 506-508, 517-521

IN8

Illustrations are concept only. Plans and specifications are subject to change without notice. Actual floor space may vary from stated floor area. See sales representative for more information. E. & O. E.

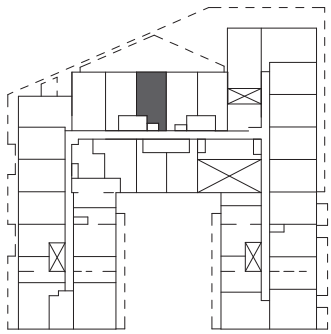

LEVEL 3

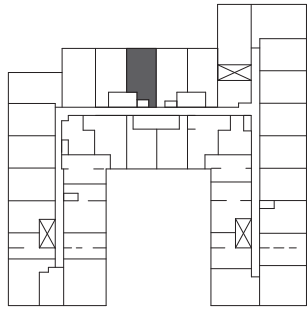

LEVEL 4

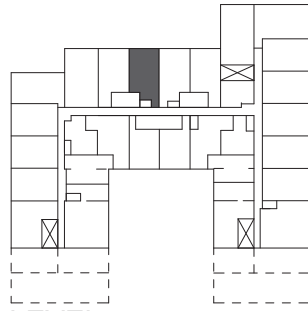

LEVEL 5

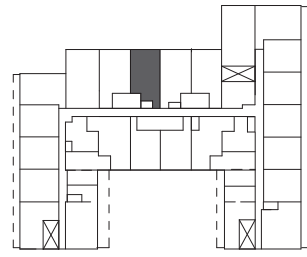

LEVEL 6-7

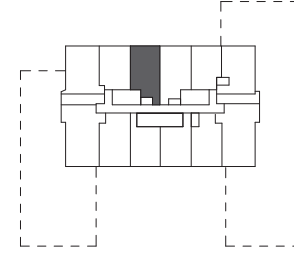

LEVEL 8



NORTH

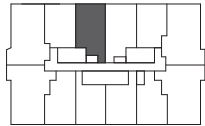

LEVEL 9-12

BALCONY 417, 512, 612,
712, 806, 906, 1006, 1106,
1206

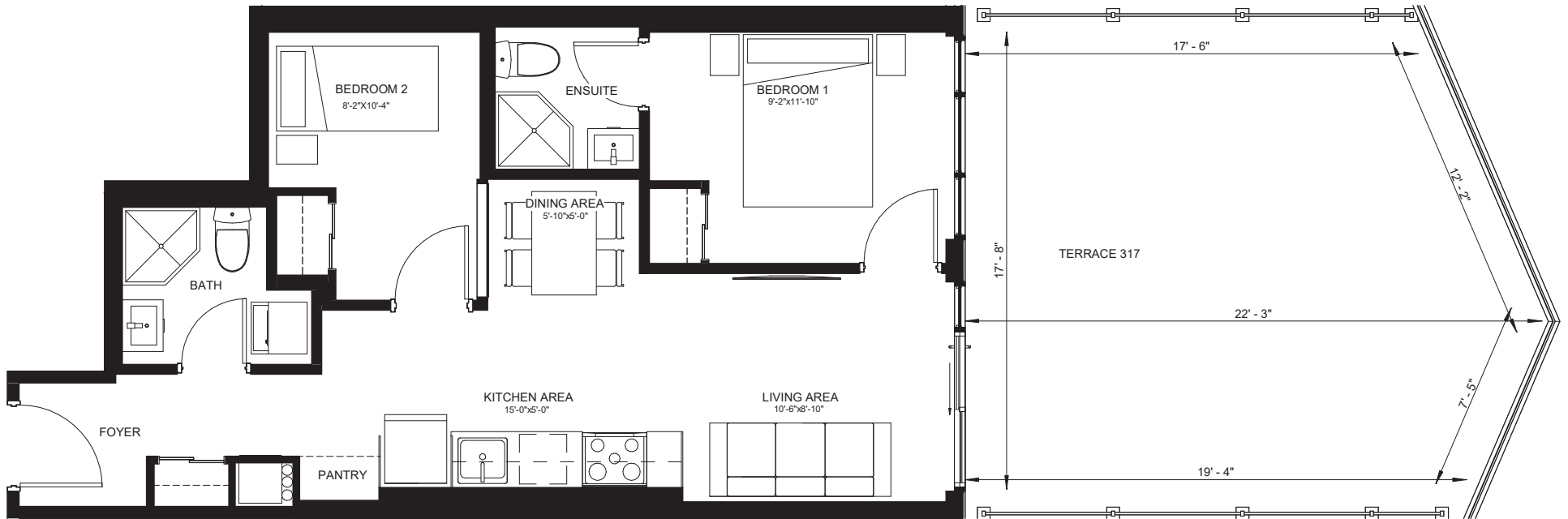
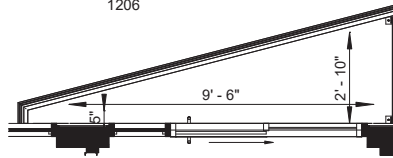

**1107
MAIN**
HAMILTON

2 BED

E613

SUITE: 613 SQ.FT.	TERRACE: 304 SQ.FT.	TOTAL: 917 SQ.FT.	UNITS: #317
SUITE: 613 SQ.FT.	BALCONY: 38 SQ.FT.	TOTAL: 651 SQ.FT.	UNITS: #417, 512
SUITE: 614 SQ.FT.	BALCONY: 43 SQ.FT.	TOTAL: 657 SQ.FT.	UNITS: #712, 806-1206

IN8

Illustrations are concept only. Plans and specifications are subject to change without notice. Actual floor space may vary from stated floor area. See sales representative for more information. E. & O. E.

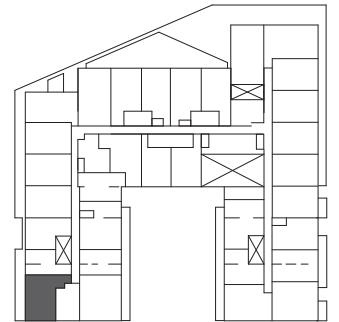
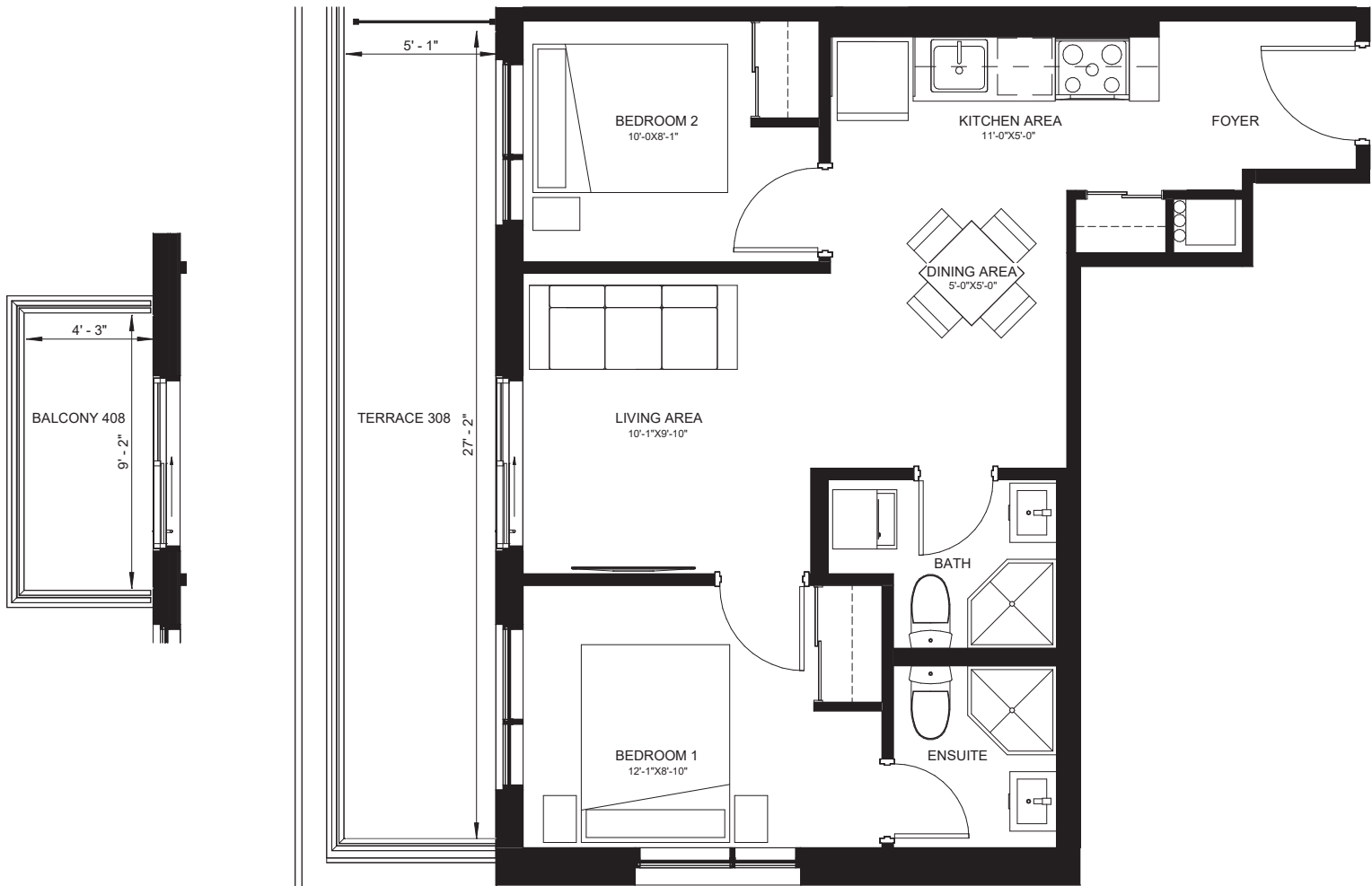

LEVEL 3

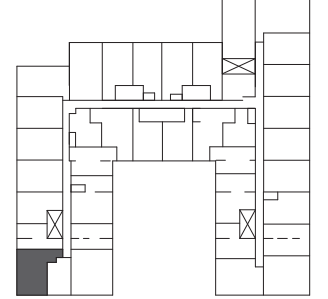

LEVEL 4

2 BED

E643

SUITE: 643 SQ.FT. TERRACE: 160 SQ.FT. TOTAL: 803 SQ.FT. | UNIT: #308

SUITE: 643 SQ.FT. BALCONY: 51 SQ.FT. TOTAL: 694 SQ.FT. | UNIT: #408

IN8

**1107
MAIN**
HAMILTON

Illustrations are concept only. Plans and specifications are subject to change without notice. Actual floor space may vary from stated floor area. See sales representative for more information. E. & O. E.

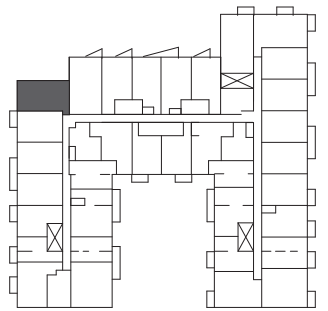
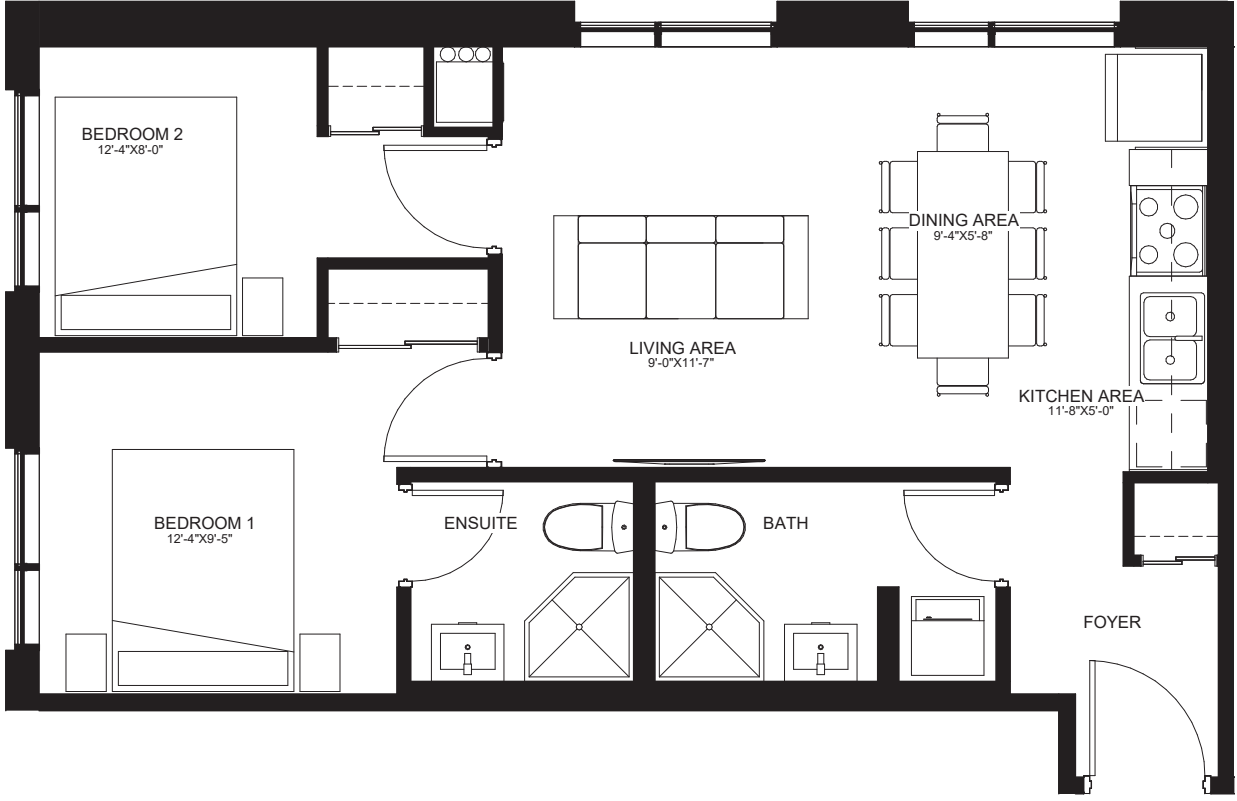

LEVEL 4

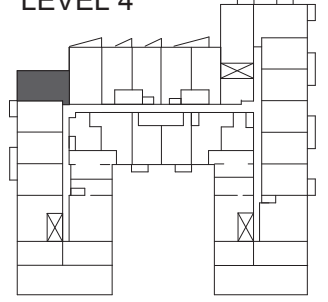

LEVEL 5

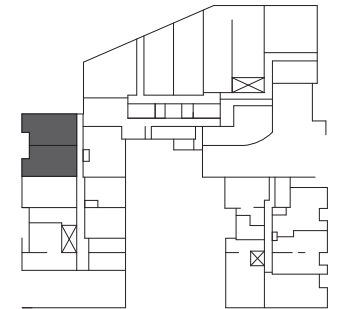
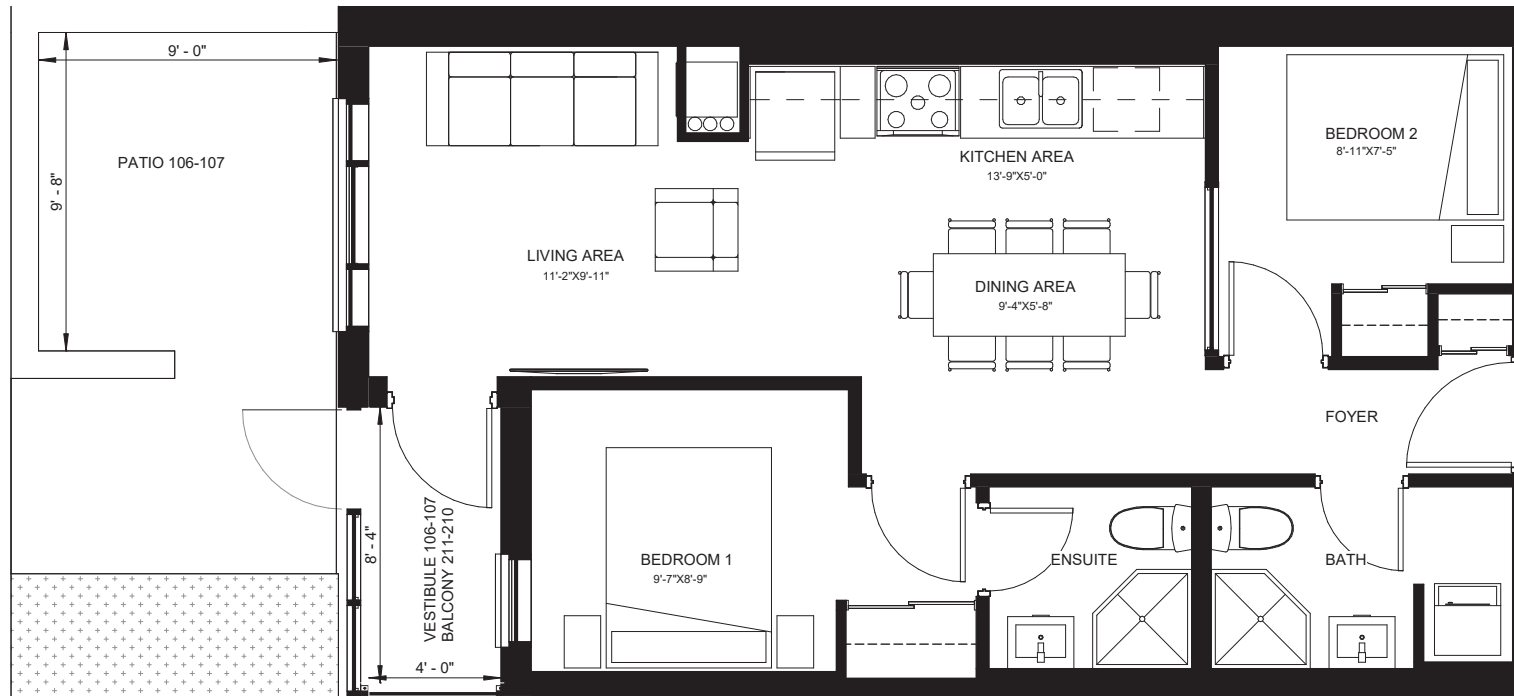

LEVEL 1

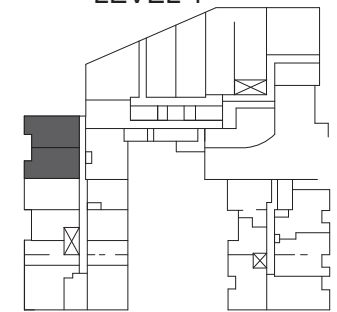

LEVEL 2

**1107
MAIN**
HAMILTON

2 BED

E707

SUITE: 707 SQ.FT. PATIO: 111 SQ.FT. TOTAL: 818 SQ.FT. | UNIT: #107
 SUITE: 689 SQ.FT. PATIO: 102 SQ.FT. TOTAL: 791 SQ.FT. | UNIT: #106
 SUITE: 707 SQ.FT. BALCONY: 42 SQ.FT. TOTAL: 749 SQ.FT. | UNIT: #211
 SUITE: 689 SQ.FT. BALCONY: 42 SQ.FT. TOTAL: 731 SQ.FT. | UNIT: #210

IN8

Illustrations are concept only. Plans and specifications are subject to change without notice. Actual floor space may vary from stated floor area. See sales representative for more information. E. & O. E.

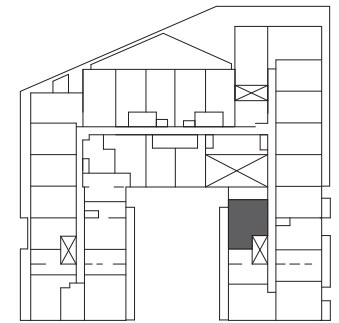

LEVEL 3

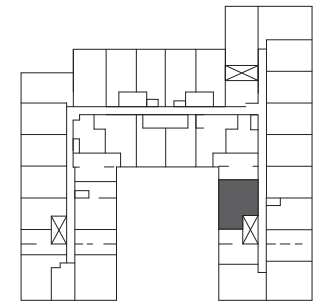

LEVEL 4

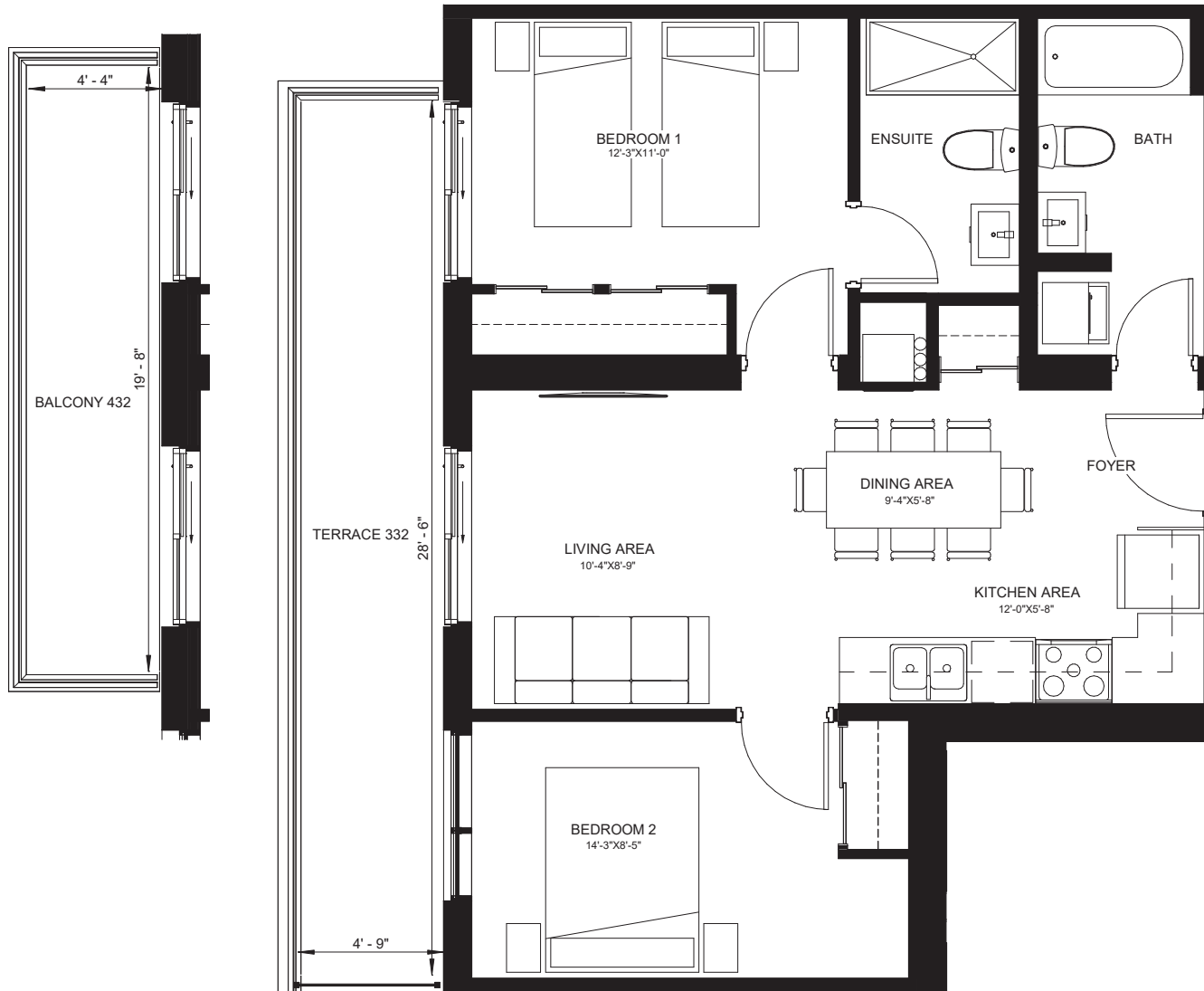

2 BED

E718

SUITE: 718 SQ.FT. TERRACE: 159 SQ.FT. TOTAL: 877 SQ.FT. | UNIT: #332

SUITE: 718 SQ.FT. BALCONY: 52 SQ.FT. TOTAL: 770 SQ.FT. | UNIT: #432

IN8

**1107
MAIN**
HAMILTON

Illustrations are concept only. Plans and specifications are subject to change without notice. Actual floor space may vary from stated floor area. See sales representative for more information. E. & O. E.

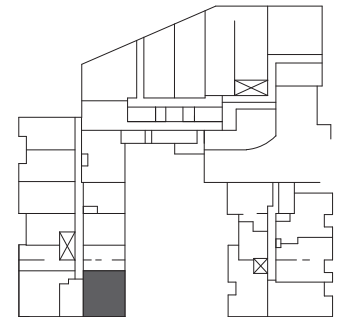
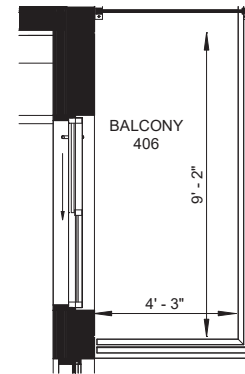
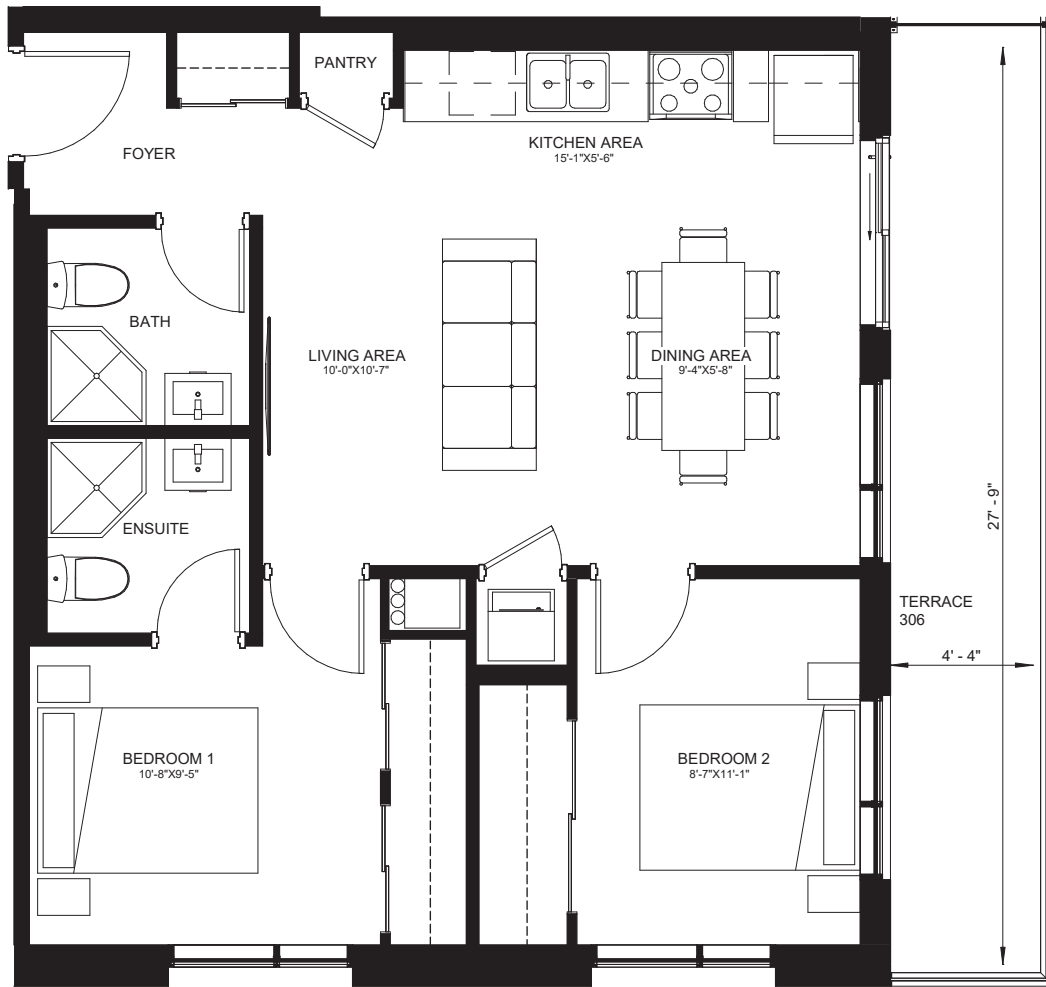

LEVEL 2

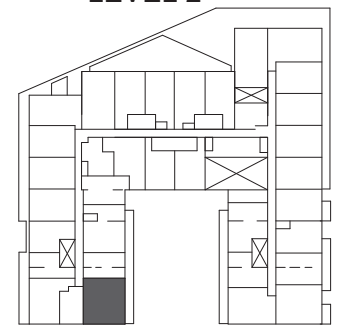

LEVEL 3

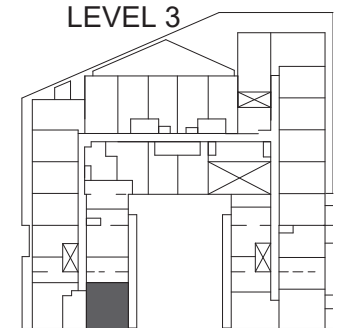

LEVEL 4

**1107
MAIN**
HAMILTON

2 BED

E767

SUITE: 767 SQ.FT. | TERRACE: 144 SQ.FT. | TOTAL: 911 SQ.FT. | UNIT: #306

SUITE: 767 SQ.FT. | UNIT: #204

SUITE: 767 SQ.FT. | BALCONY: 51 SQ.FT. | TOTAL: 818 SQ.FT. | UNIT: #406

IN8

Illustrations are concept only. Plans and specifications are subject to change without notice. Actual floor space may vary from stated floor area. See sales representative for more information. E. & O. E.

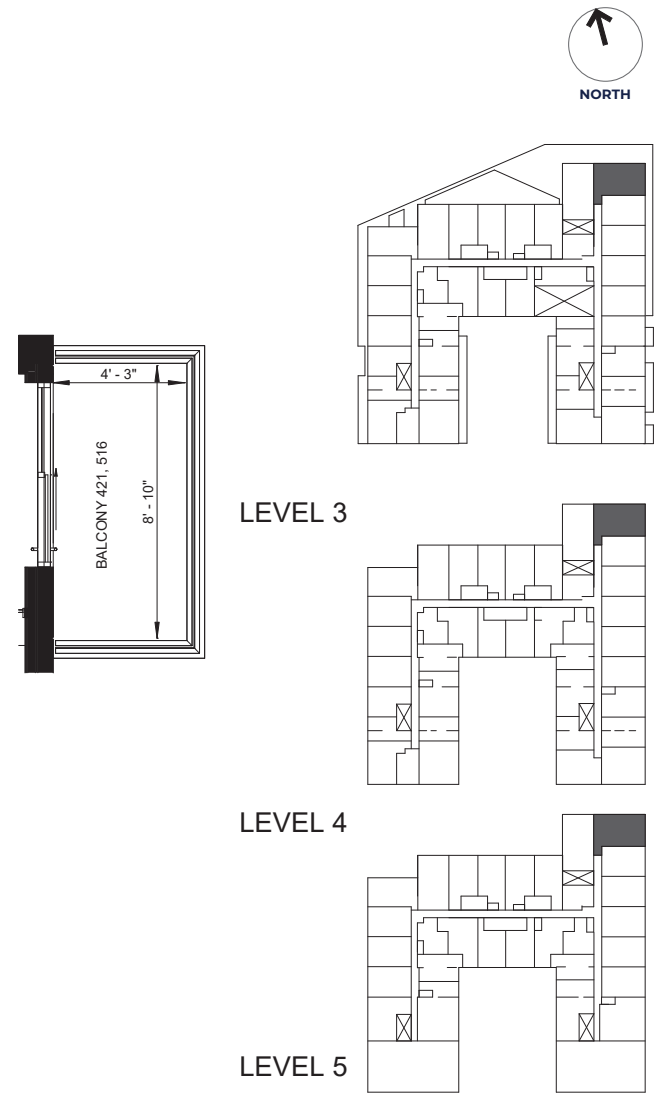

**1107
MAIN**
HAMILTON

2 BED
E780

SUITE: 780 SQ.FT. TERRACE: 207 SQ.FT. BALCONY: 123 SQ.FT. TOTAL: 1110 SQ.FT. | UNIT: #321
 SUITE: 780 SQ.FT. BALCONIES: 100 SQ.FT. TOTAL: 880 SQ.FT. | UNITS: #421, 516

IN8

Illustrations are concept only. Plans and specifications are subject to change without notice. Actual floor space may vary from stated floor area. See sales representative for more information. E. & O. E.

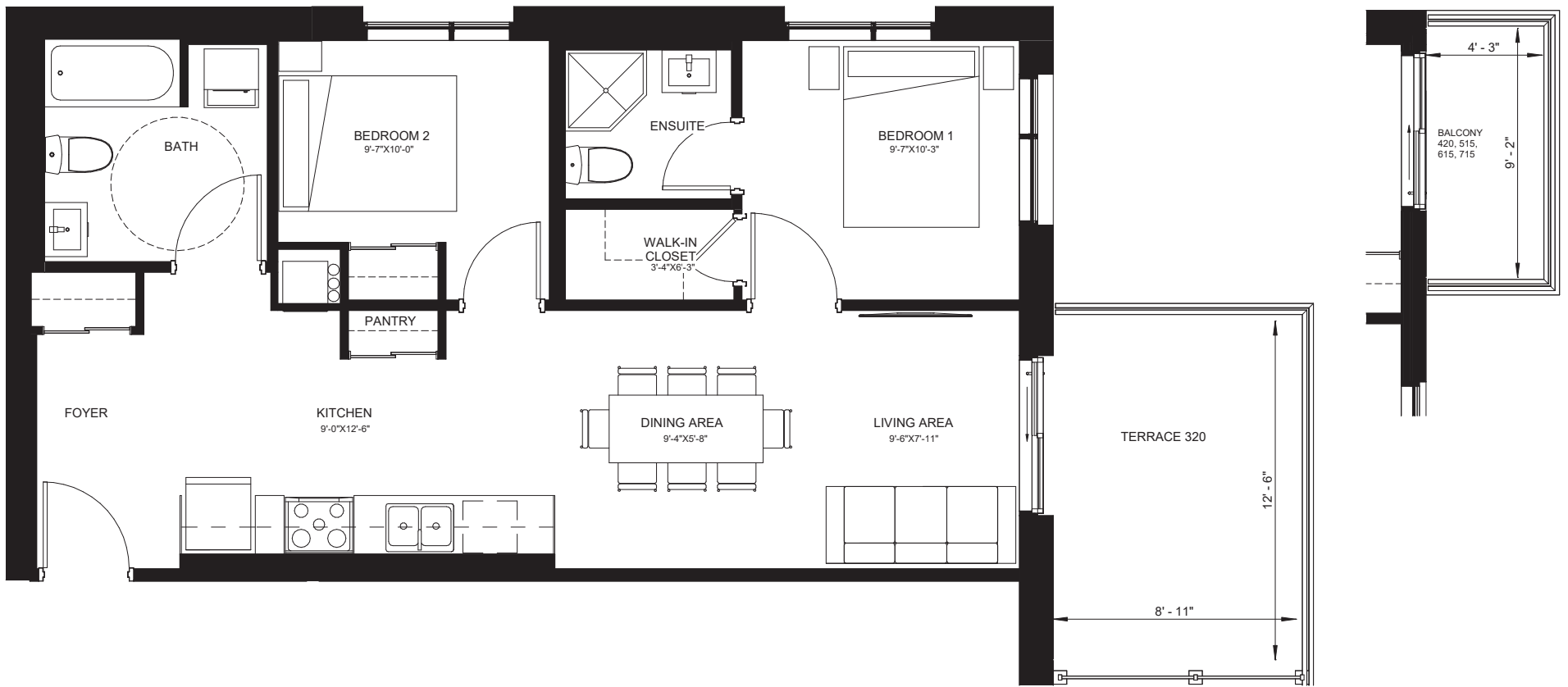

NORTH

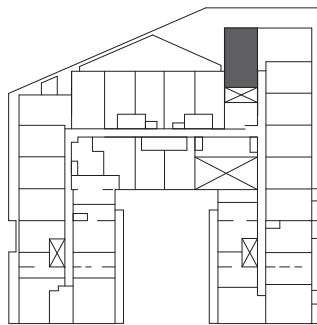

LEVEL 3-4

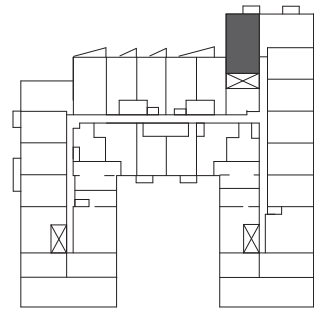

LEVEL 5

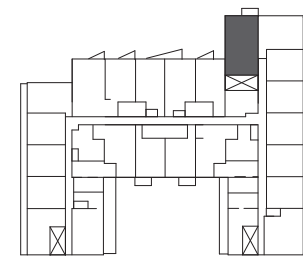

LEVEL 6

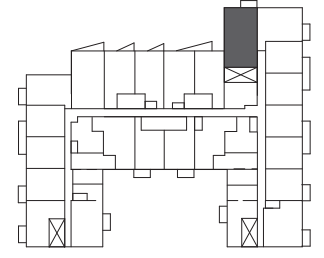

LEVEL 7

**1107
MAIN**
HAMILTON

2 BED

E789

SUITE: 789 SQ.FT.

TERRACE: 132 SQ.FT.

TOTAL: 921 SQ.FT. | UNIT: #320

SUITE: 792 SQ.FT.

BALCONY: 53 SQ.FT.

TOTAL: 845 SQ.FT. | UNITS: #420, 515-715

IN8

Illustrations are concept only. Plans and specifications are subject to change without notice. Actual floor space may vary from stated floor area. See sales representative for more information. E. & O. E.

TYPICAL KEYPLATES

- STUDIO
- 1 BED
- 1 BED + DEN
- 2 BED
- 3 BED

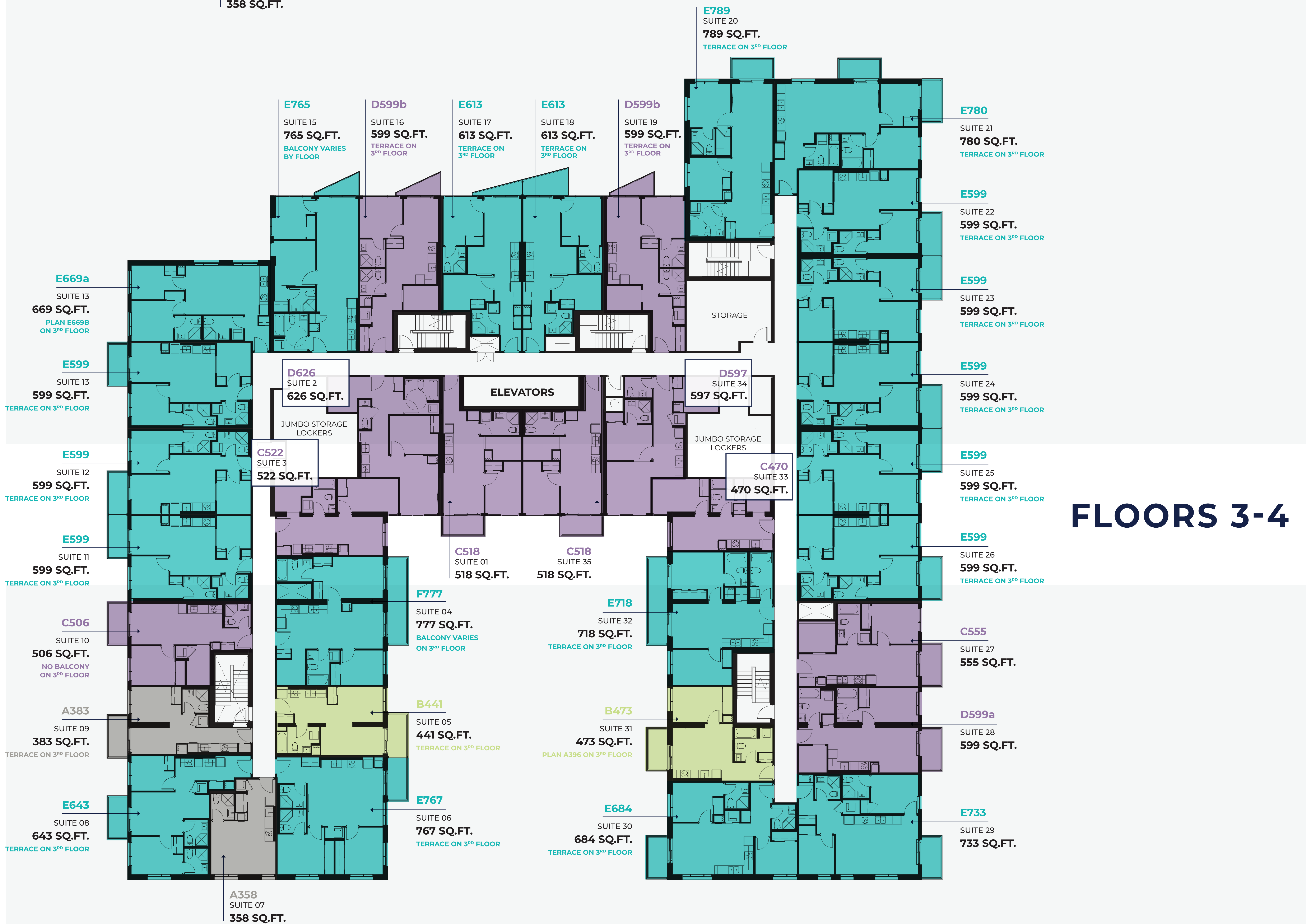

Plans and specifications are subject to change without notice. Actual usable floor space may vary from stated floor area. Illustrations are artists concept only and may show optional features not included in base price. See sales representative for further information. E. & O. E.

