

LEVELS 9-12

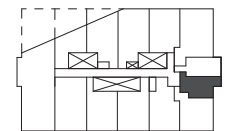

LEVEL 13

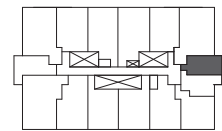
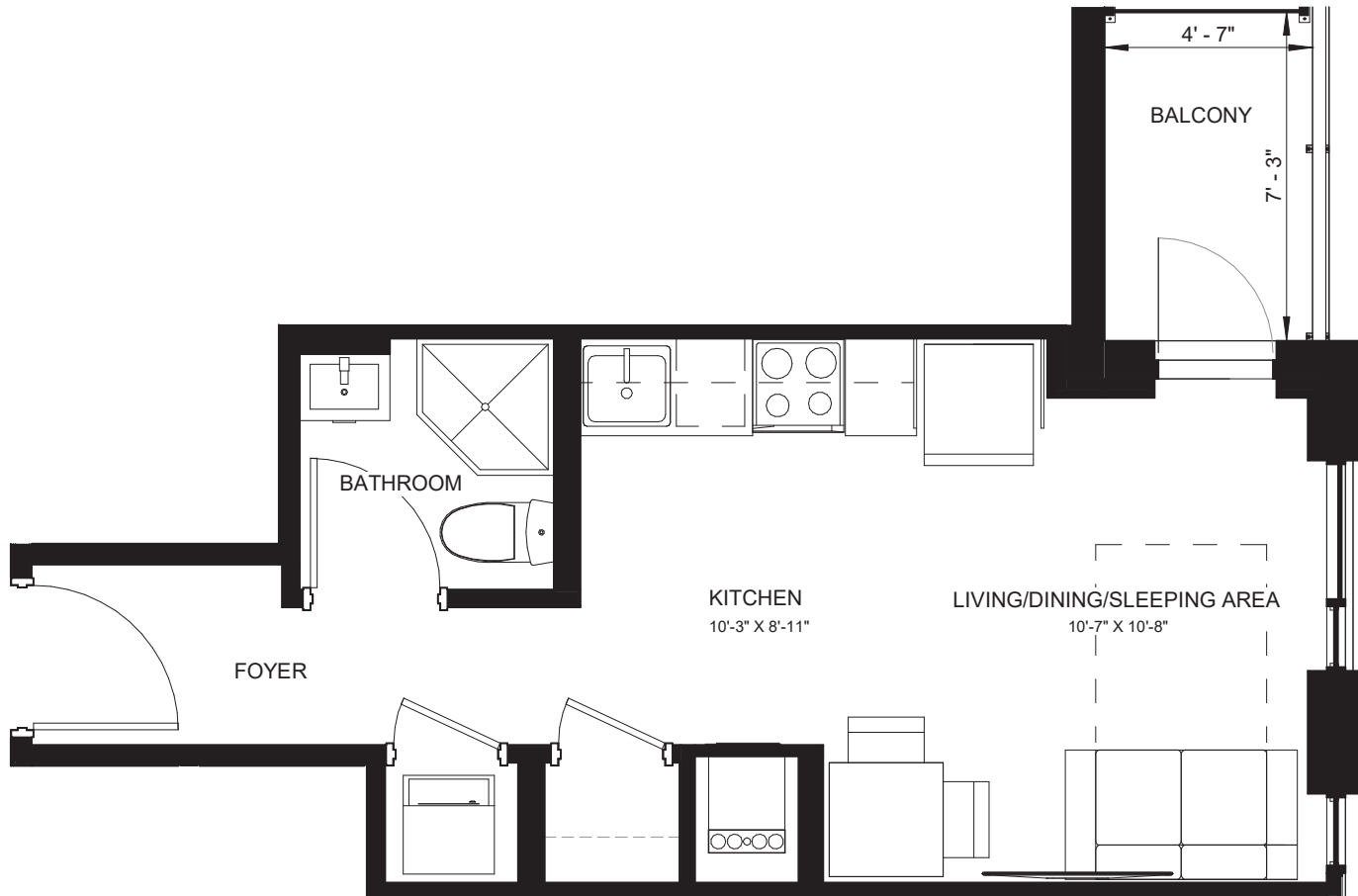

LEVELS 9-12

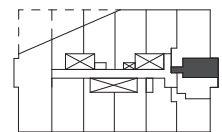

LEVEL 13



STUDIO

A312

SUITE: 312 SQ.FT. BALCONY: 36 SQ.FT. TOTAL: 348 SQ.FT. | UNITS: #911-1211, 1309



Illustrations are concept only. Plans and specifications are subject to change without notice. Actual floor space may vary from stated floor area. See sales representative for more information. E. & O. E.

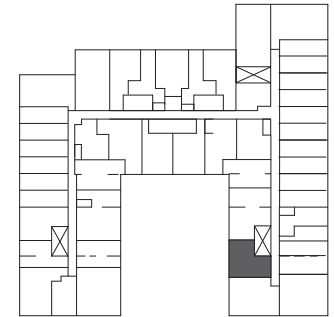
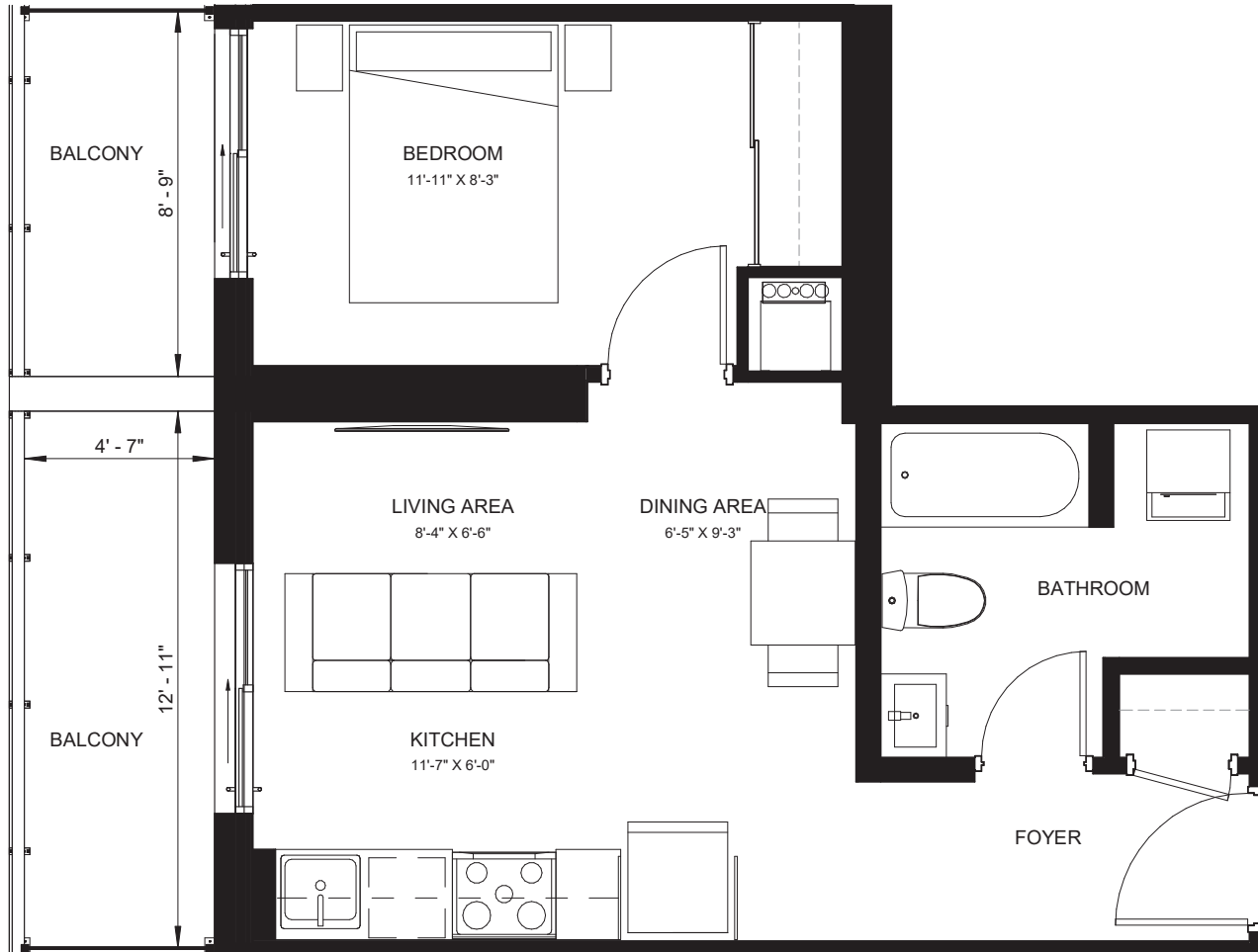

LEVEL 4

**1107
MAIN**
HAMILTON

1 BED

B473

SUITE: 473 SQ.FT. BALCONY: 111 SQ.FT. TOTAL: 584 SQ.FT. | UNIT: #441

IN8

Illustrations are concept only. Plans and specifications are subject to change without notice. Actual floor space may vary from stated floor area. See sales representative for more information. E. & O. E.

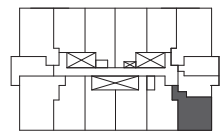
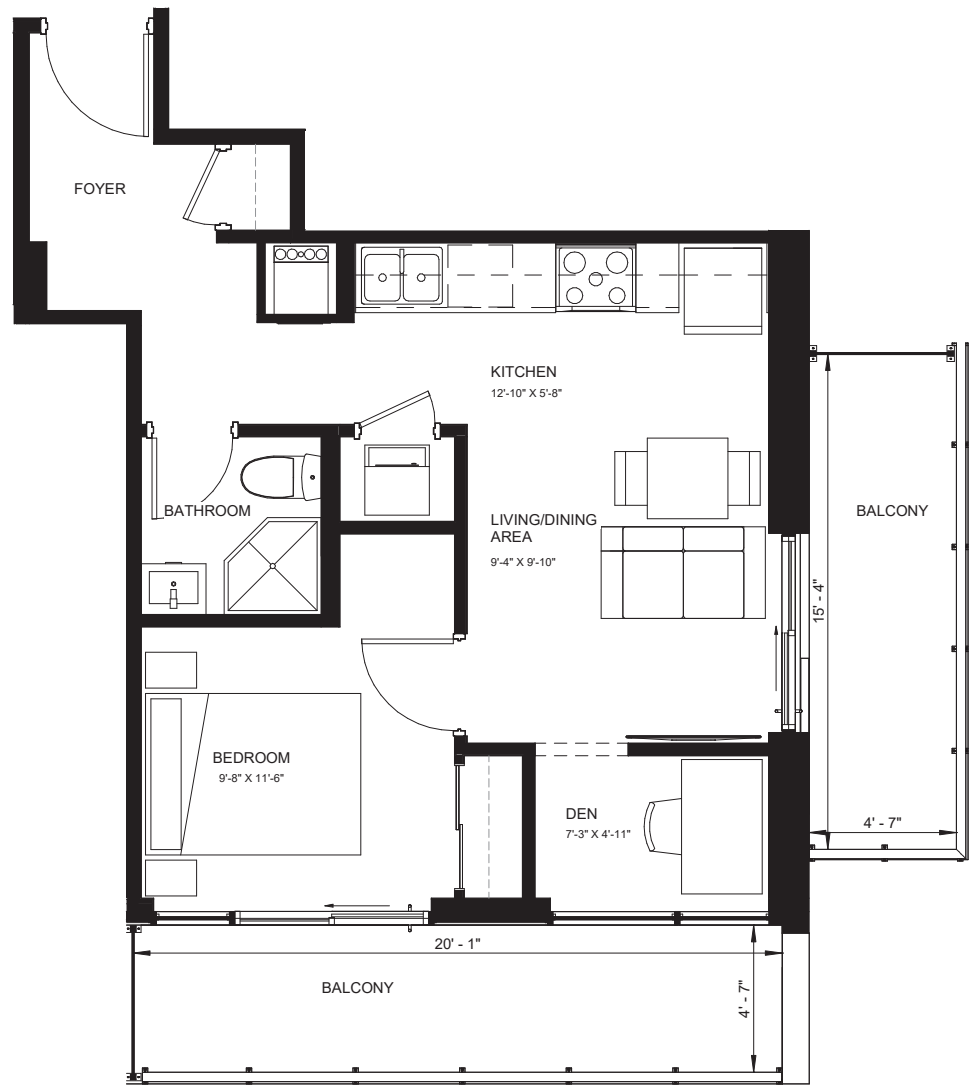

LEVELS 9-12

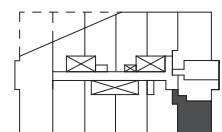

LEVEL 13

**1107
MAIN**
HAMILTON

1 BED + DEN

C497

SUITE: 497 SQ.FT. BALCONY: 200 SQ.FT. TOTAL: 697 SQ.FT. | UNITS: #913-1213, 1311

IN8

Illustrations are concept only. Plans and specifications are subject to change without notice. Actual floor space may vary from stated floor area. See sales representative for more information. E. & O. E.

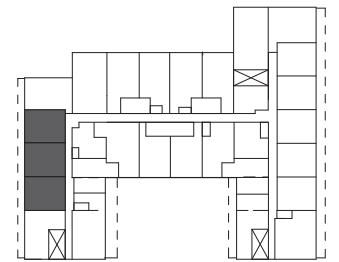

LEVEL 6

1 BED + DEN

C498t

SUITE: 498 SQ.FT.

TERRACE: 91 SQ.FT.

TOTAL: 589 SQ.FT. | UNITS: #606-608

IN8

1107
MAIN
HAMILTON

Illustrations are concept only. Plans and specifications are subject to change without notice. Actual floor space may vary from stated floor area. See sales representative for more information. E. & O. E.

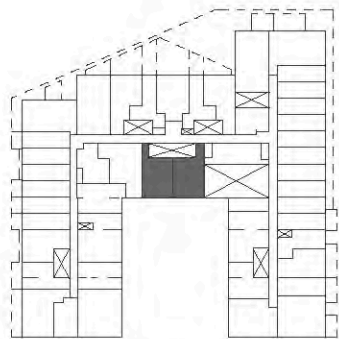
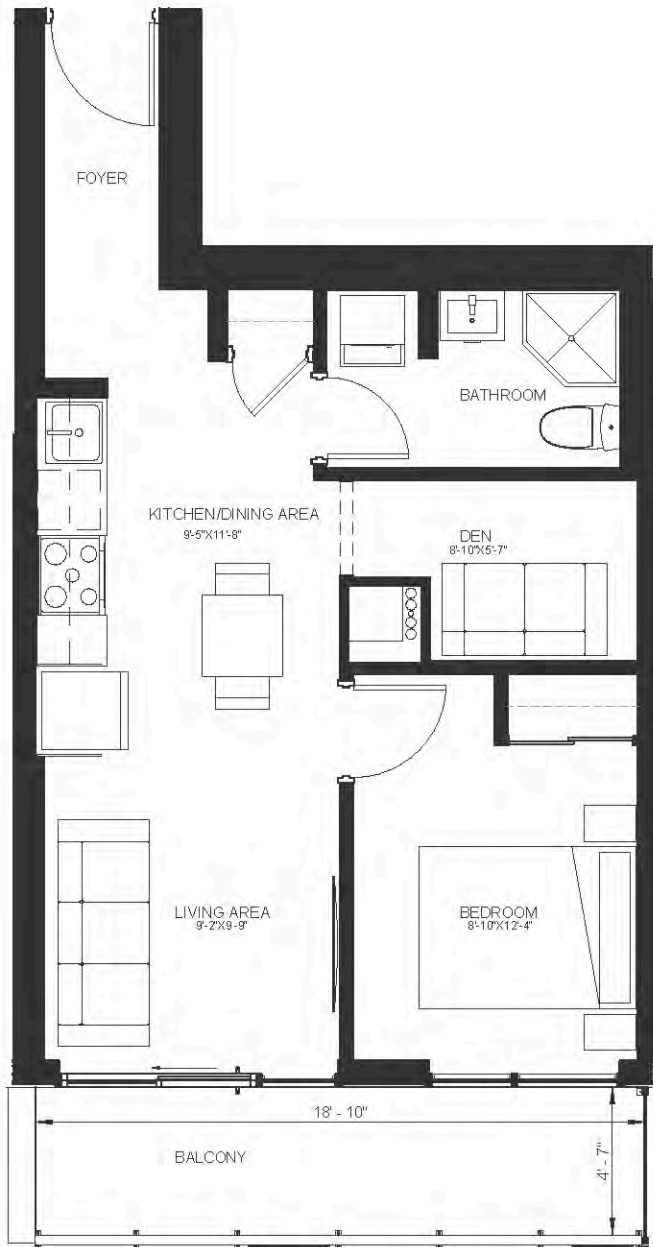

LEVEL 3

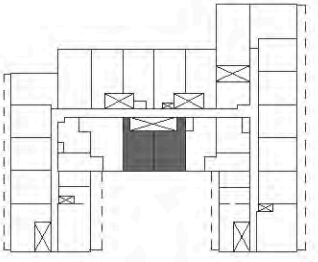

LEVELS 6-7

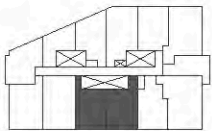

LEVELS 14-15

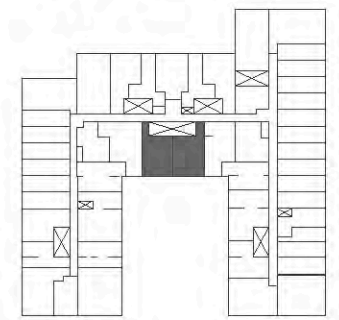

LEVEL 4

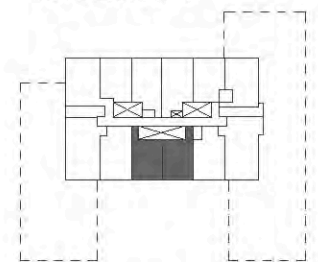

LEVEL 8

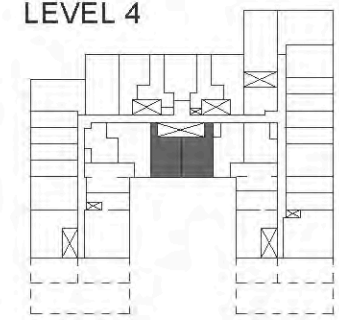

LEVEL 5

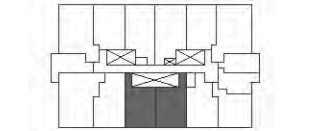

LEVELS 9-12

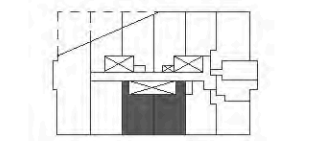

LEVEL 13

**1107
MAIN**
HAMILTON

1 BED + DEN

**C517
/521**

SUITE: 517 SQ.FT. BALCONY: 95 SQ.FT. TOTAL: 612 SQ.FT. | UNITS: #301-1501

SUITE: 521 SQ.FT. BALCONY: 95 SQ.FT. TOTAL: 616 SQ.FT. |

UNITS: #343, 446, 533, 627, 727, 812-1212, 1311-1511

IN8

Illustrations are concept only. Plans and specifications are subject to change without notice. Actual floor space may vary from stated floor area. See sales representative for more information. E. & O. E.

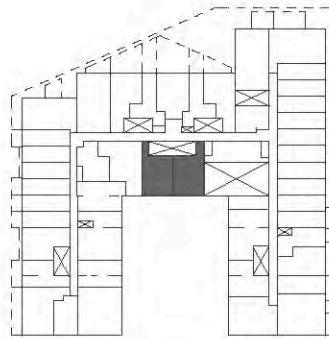
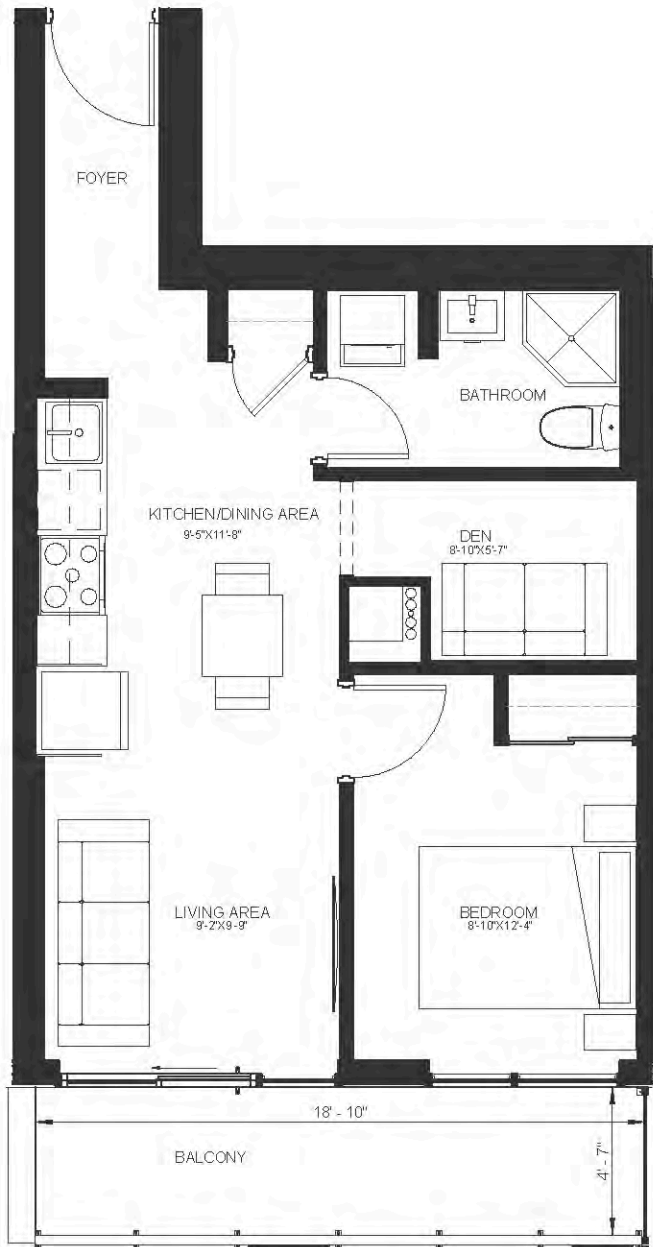

LEVEL 3

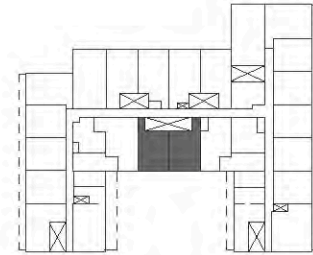

LEVELS 6-7

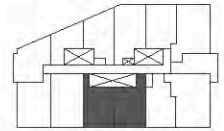

LEVELS 14-15

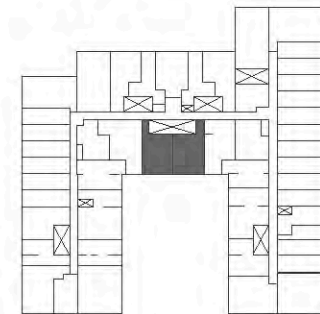

LEVEL 4

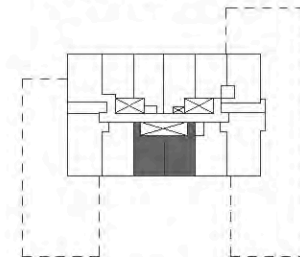

LEVEL 8

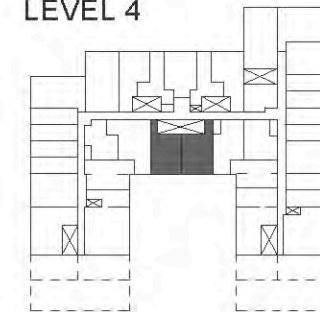

LEVEL 5

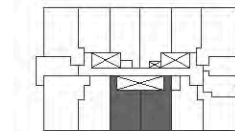

LEVELS 9-12

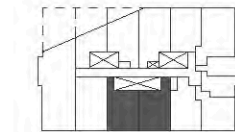

LEVEL 13

**1107
MAIN**
HAMILTON

1 BED + DEN

**C517
/521**

SUITE: 517 SQ.FT. BALCONY: 95 SQ.FT. TOTAL: 612 SQ.FT. | UNITS: #301-1501
 SUITE: 521 SQ.FT. BALCONY: 95 SQ.FT. TOTAL: 616 SQ.FT. |
 UNITS: #343, 446, 533, 627, 727, 812-1212, 1311-1511

IN8

Illustrations are concept only. Plans and specifications are subject to change without notice. Actual floor space may vary from stated floor area. See sales representative for more information. E. & O. E.

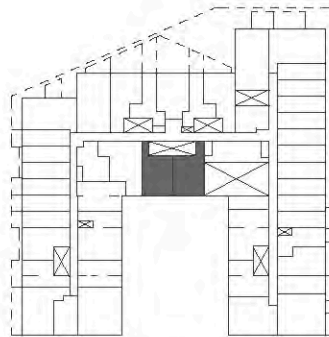
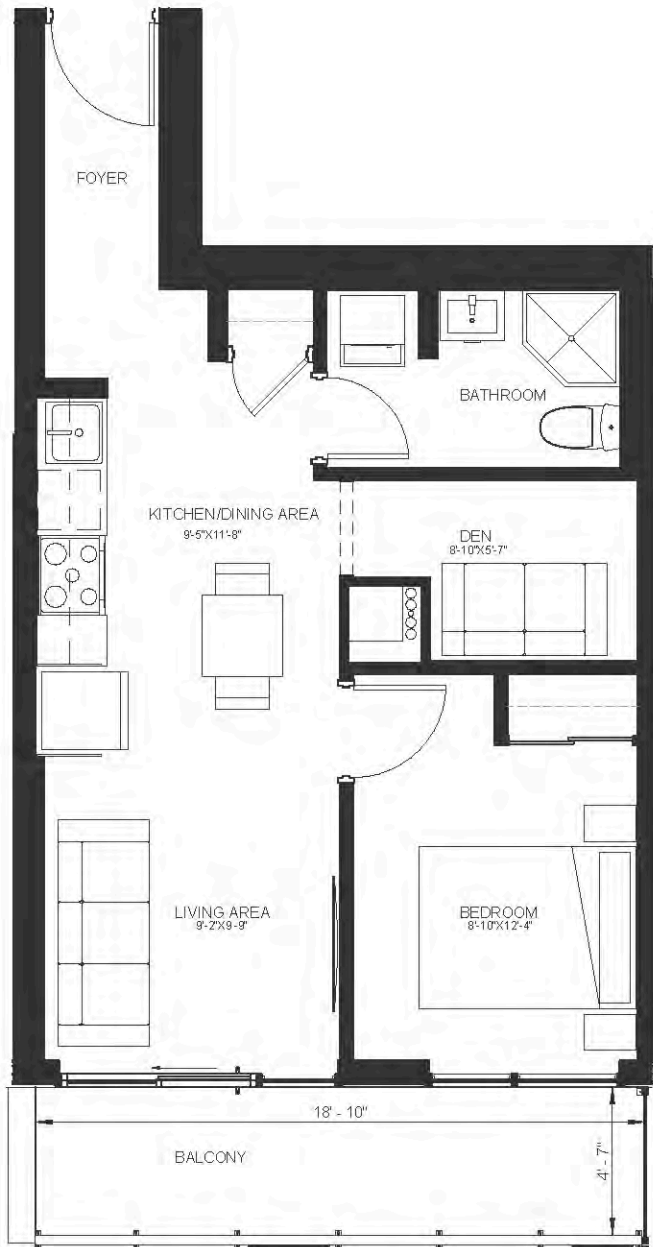

LEVEL 3

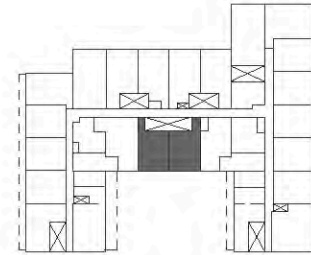

LEVELS 6-7

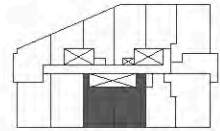

LEVELS 14-15

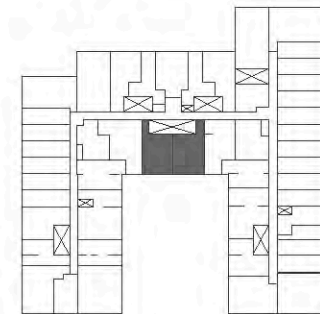

LEVEL 4

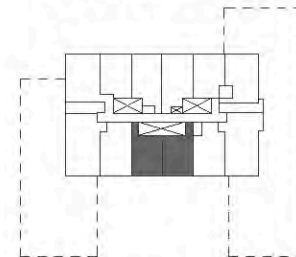

LEVEL 8

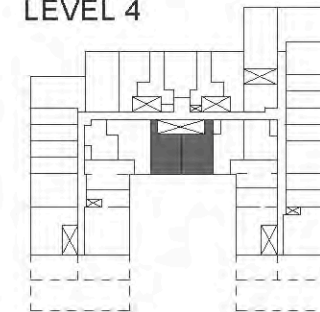

LEVEL 5

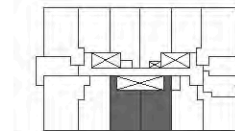

LEVELS 9-12

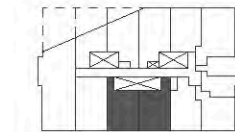

LEVEL 13

**1107
MAIN**
HAMILTON

1 BED + DEN

**C517
/521**

SUITE: 517 SQ.FT. BALCONY: 95 SQ.FT. TOTAL: 612 SQ.FT. | UNITS: #301-1501

SUITE: 521 SQ.FT. BALCONY: 95 SQ.FT. TOTAL: 616 SQ.FT. |

UNITS: #343, 446, 533, 627, 727, 812-1212, 1311-1511

IN8

Illustrations are concept only. Plans and specifications are subject to change without notice. Actual floor space may vary from stated floor area. See sales representative for more information. E. & O. E.

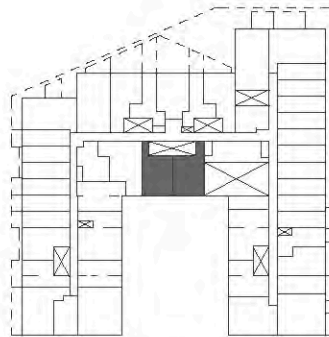
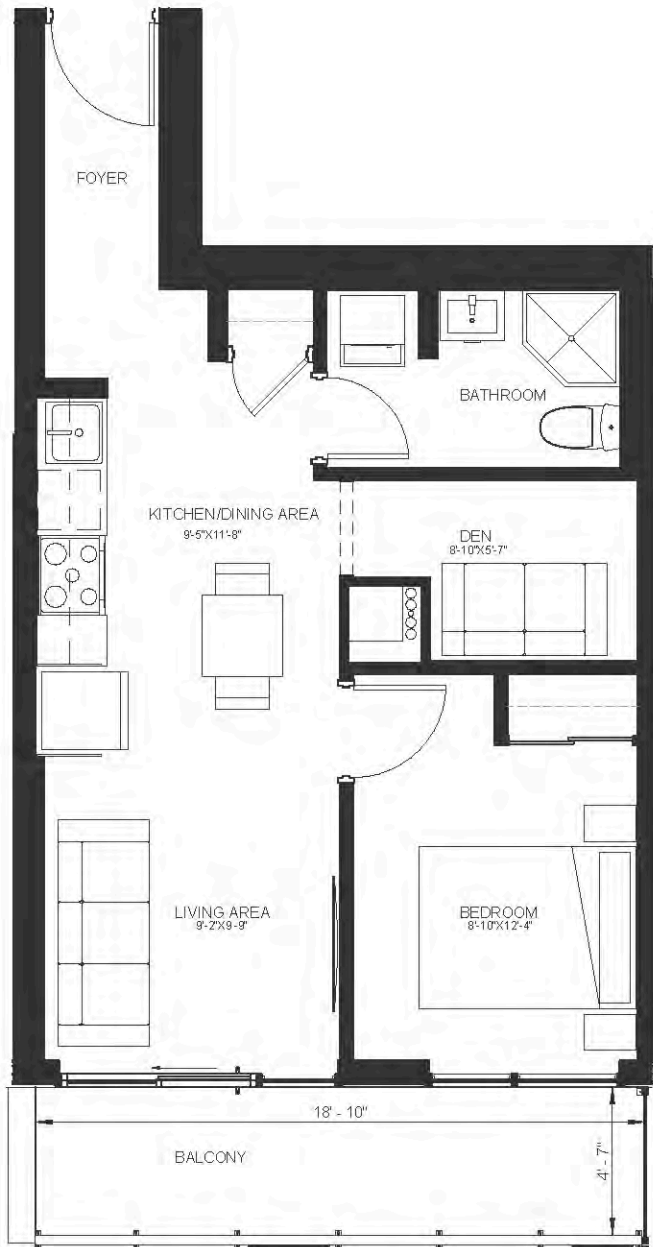

LEVEL 3

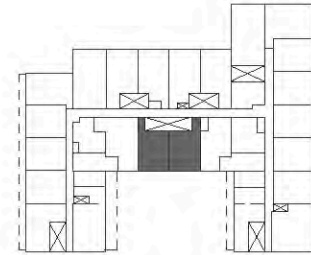

LEVELS 6-7

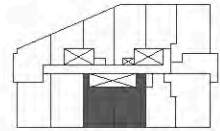

LEVELS 14-15

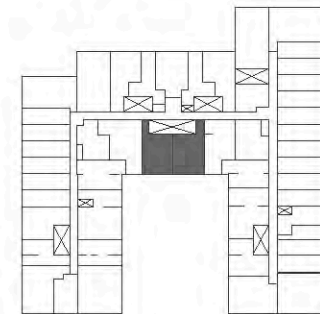

LEVEL 4

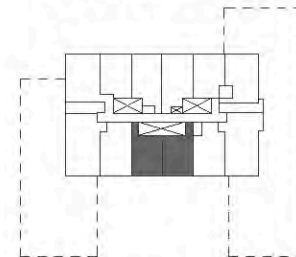

LEVEL 8

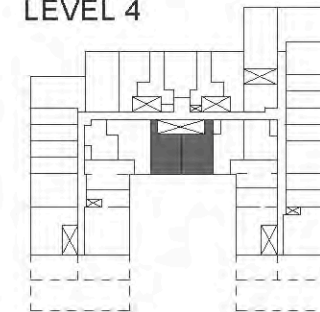

LEVEL 5

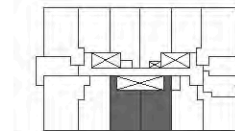

LEVELS 9-12

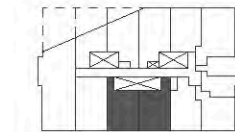

LEVEL 13

**1107
MAIN**
HAMILTON

1 BED + DEN

**C517
/521**

SUITE: 517 SQ.FT. BALCONY: 95 SQ.FT. TOTAL: 612 SQ.FT. | UNITS: #301-1501

SUITE: 521 SQ.FT. BALCONY: 95 SQ.FT. TOTAL: 616 SQ.FT. |

UNITS: #343, 446, 533, 627, 727, 812-1212, 1311-1511

IN8

Illustrations are concept only. Plans and specifications are subject to change without notice. Actual floor space may vary from stated floor area. See sales representative for more information. E. & O. E.

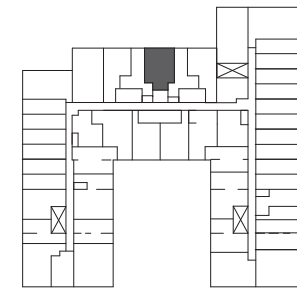

LEVEL 4

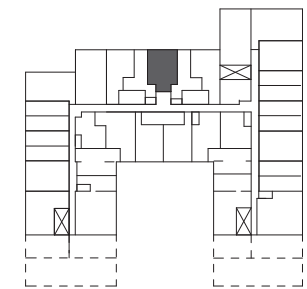

LEVEL 5

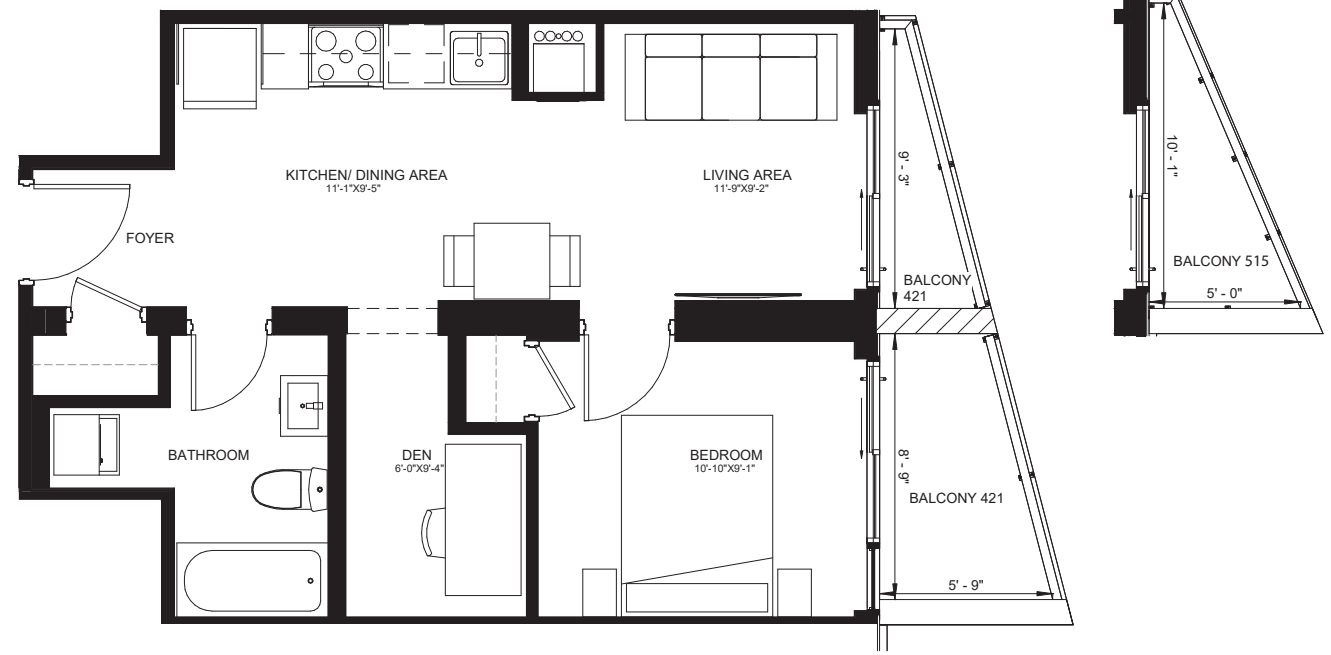

1 BED + DEN

C526

SUITE: 526 SQ.FT.
SUITE: 526 SQ.FT.

BALCONY: 38 SQ.FT.
BALCONY: 76 SQ.FT.

TOTAL: 564 SQ.FT. | UNITS: #515
TOTAL: 602 SQ.FT. | UNITS: #421

IN8

1107
MAIN
HAMILTON

Illustrations are concept only. Plans and specifications are subject to change without notice. Actual floor space may vary from stated floor area. See sales representative for more information. E. & O. E.

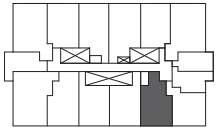
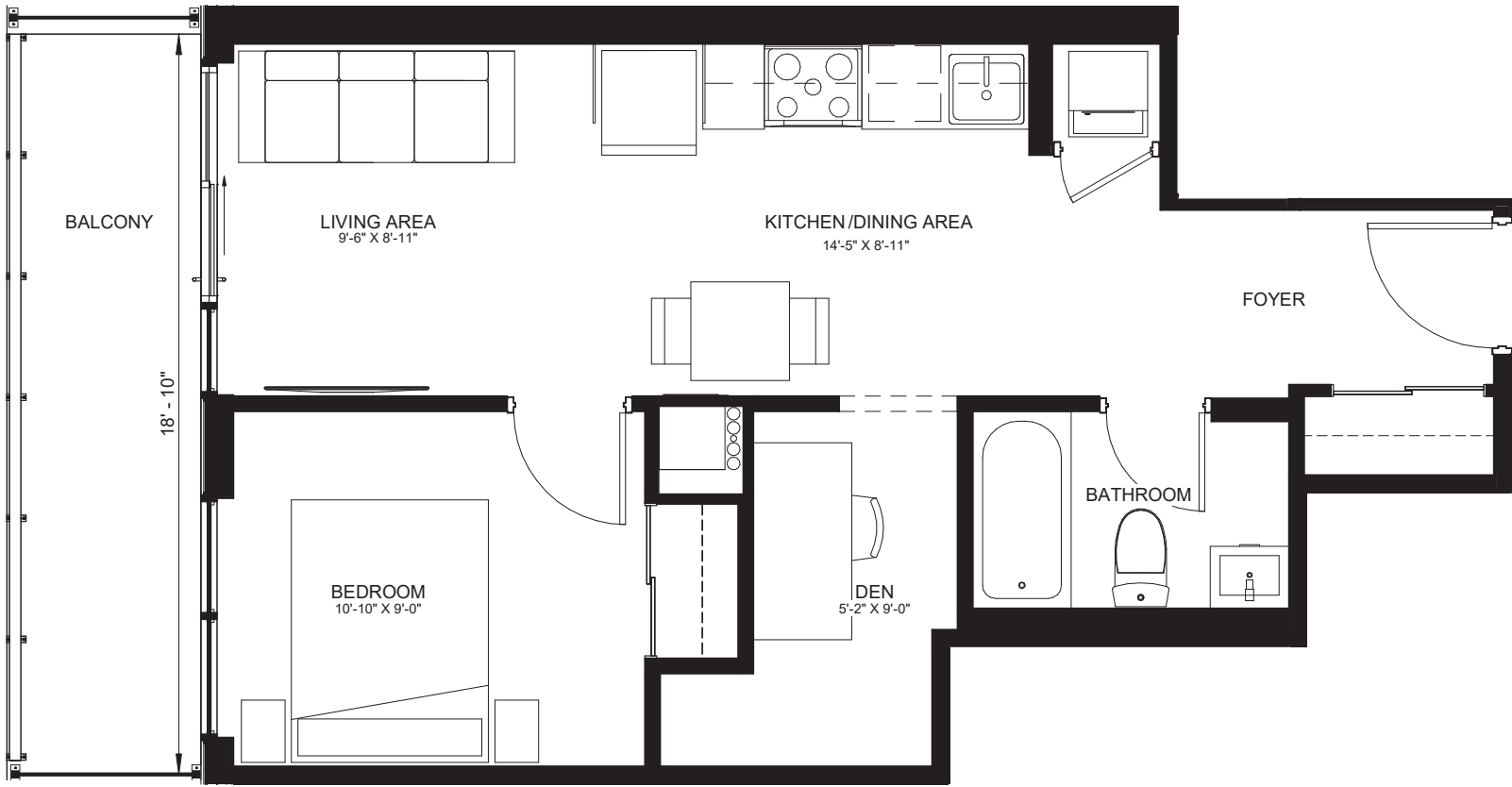

LEVELS 9-12

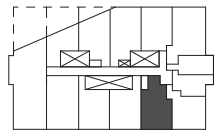

LEVEL 13

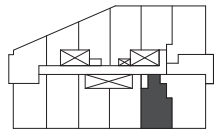

LEVELS 14-15

1 BED + DEN

C527

SUITE: 527 SQ.FT.

BALCONY: 95 SQ.FT.

TOTAL: 622 SQ.FT.

UNITS: #911-1211, 1310-1510

1107
MAIN
HAMILTON

IN8

Illustrations are concept only. Plans and specifications are subject to change without notice. Actual floor space may vary from stated floor area. See sales representative for more information. E. & O. E.

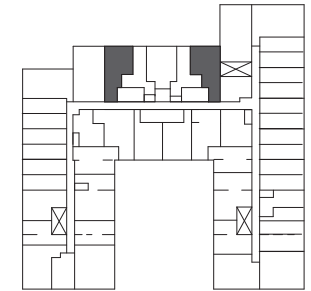
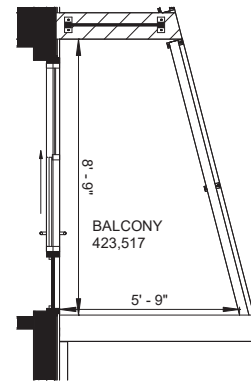

LEVEL 4

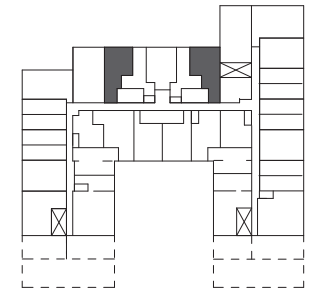

LEVEL 5

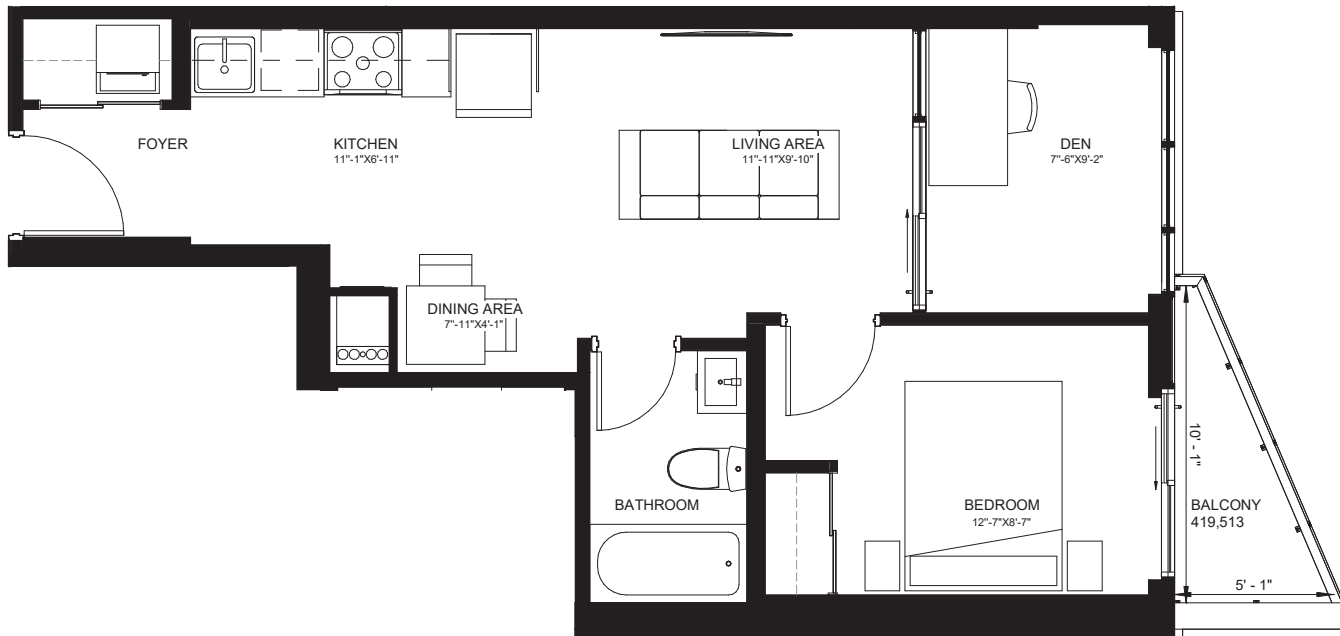

1 BED + DEN

C534

SUITE: 537 SQ.FT.

BALCONY: 38 SQ.FT.

TOTAL: 575 SQ.FT.

UNITS: #419, 513

SUITE: 534 SQ.FT.

BALCONY: 55 SQ.FT.

TOTAL: 589 SQ.FT.

UNIT: #423, 517

IN8

1107
MAIN
HAMILTON

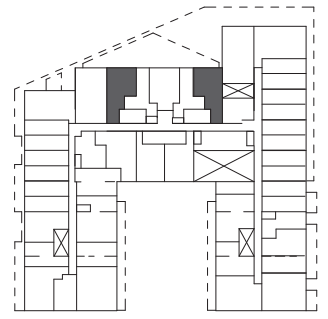
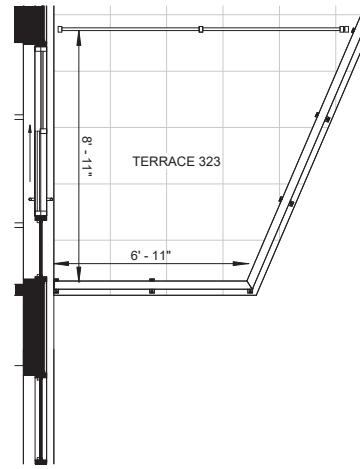

LEVEL 3

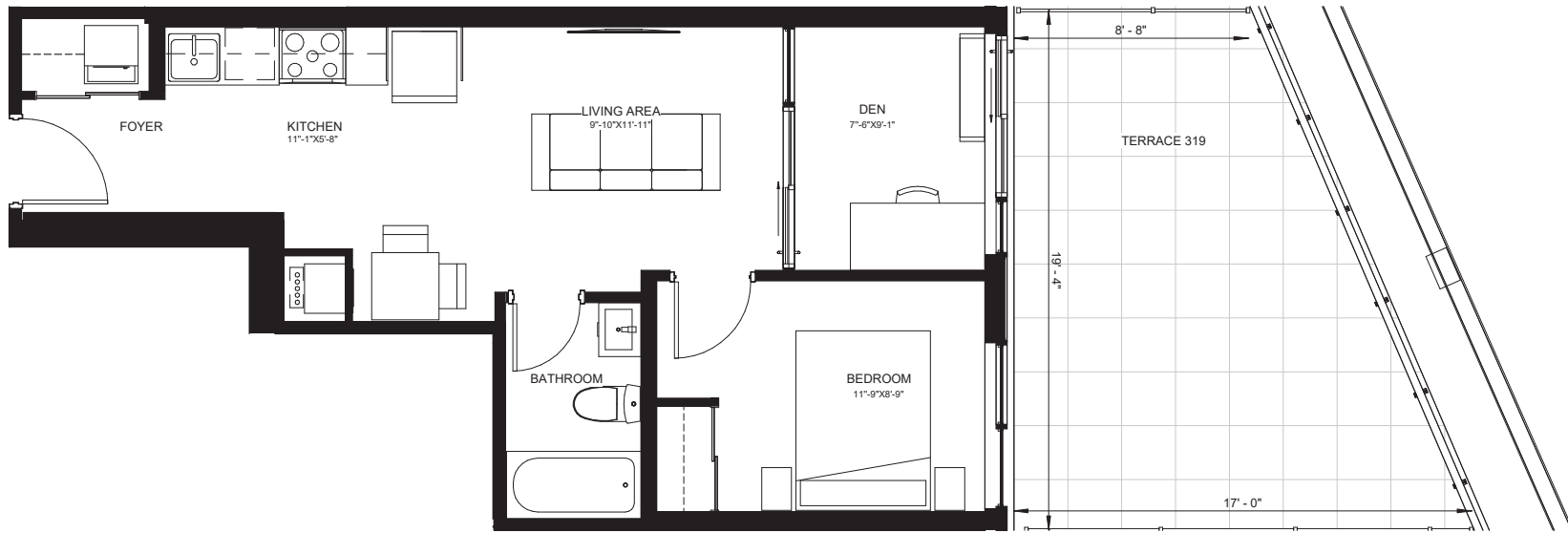

1 BED + DEN

C534t

SUITE: 536 SQ.FT.

TERRACE: 265 SQ.FT.

TOTAL: 801 SQ.FT. | UNIT: #319

SUITE: 534 SQ.FT.

TERRACE: 89 SQ.FT.

TOTAL: 623 SQ.FT. | UNIT: #323

IN8

1107
MAIN
HAMILTON

Illustrations are concept only. Plans and specifications are subject to change without notice. Actual floor space may vary from stated floor area. See sales representative for more information. E. & O. E.



NORTH

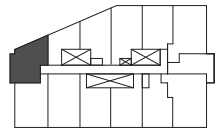

LEVELS 14-15

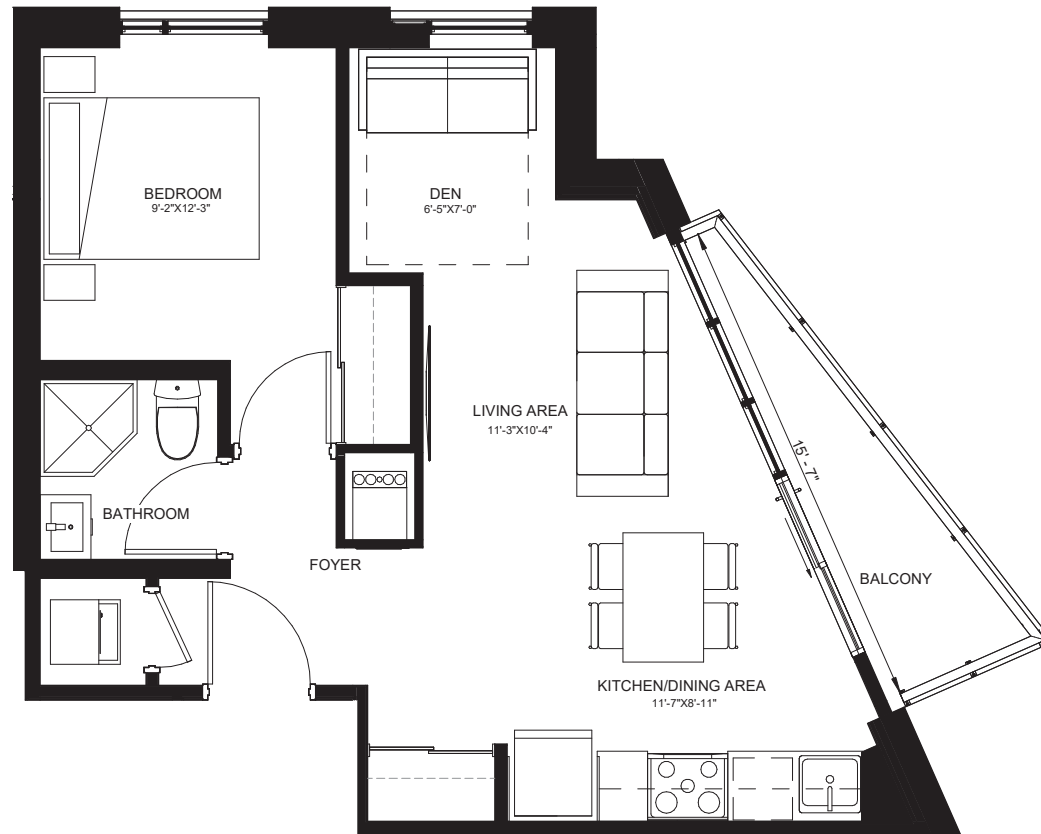

1 BED + DEN

C547

SUITE: 547 SQ.FT.

BALCONY: 44 SQ.FT.

TOTAL: 591 SQ.FT. |

UNIT: #1404, 1504

IN8

1107
MAIN
HAMILTON

Illustrations are concept only. Plans and specifications are subject to change without notice. Actual floor space may vary from stated floor area. See sales representative for more information. E. & O. E.

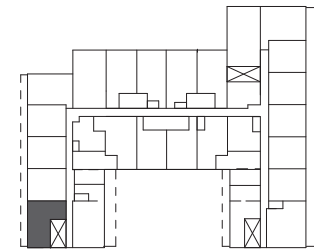

LEVEL 7

**1107
MAIN**
HAMILTON

1 BED + DEN

C548

SUITE: 548 SQ.FT. BALCONY: 100 SQ.FT. TOTAL: 648 SQ.FT. | UNIT: #705

IN8

Illustrations are concept only. Plans and specifications are subject to change without notice. Actual floor space may vary from stated floor area. See sales representative for more information. E. & O. E.

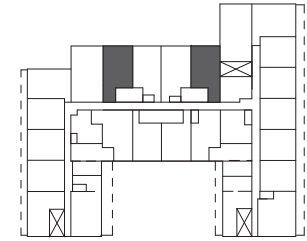

LEVEL 6-7

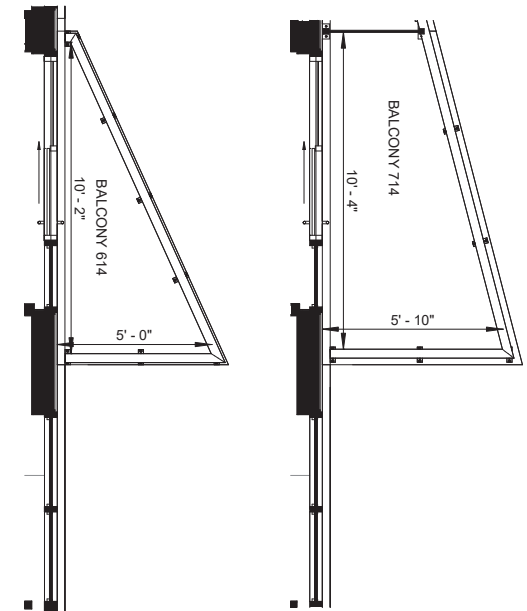
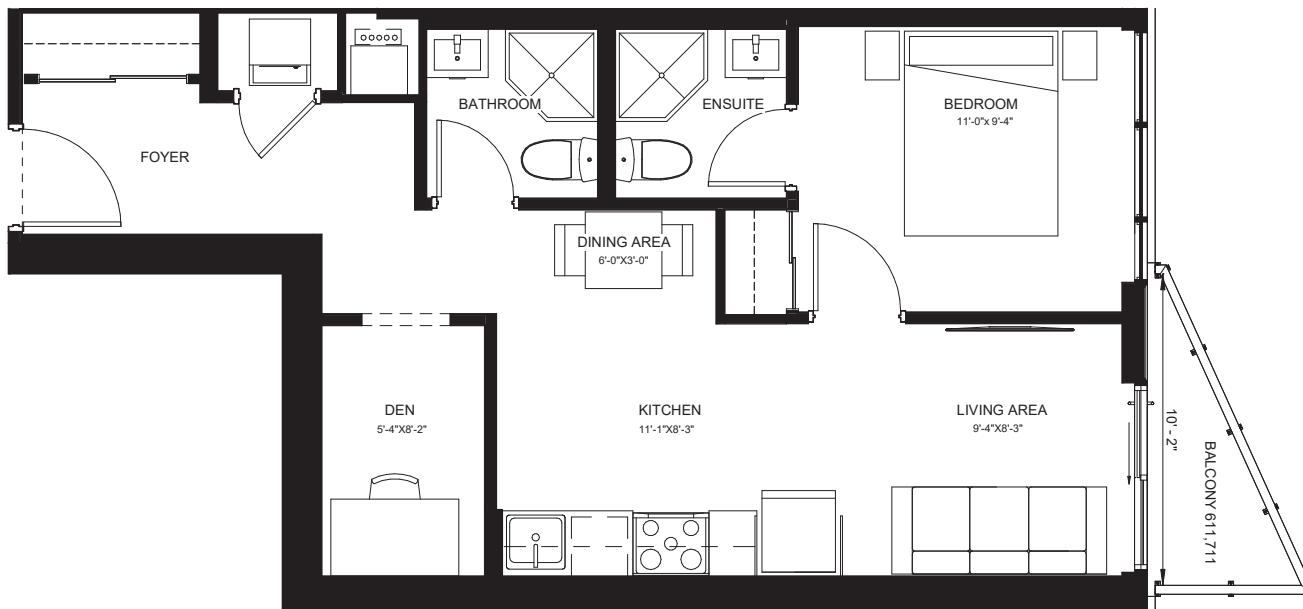

**1107
MAIN**
HAMILTON

1 BED + DEN

D599

SUITE: 599 SQ.FT.

SUITE: 597 SQ.FT.

SUITE: 597 SQ.FT.

BALCONY: 33 SQ.FT.

BALCONY: 33 SQ.FT.

BALCONY: 55 SQ.FT.

TOTAL: 632 SQ.FT.

TOTAL: 630 SQ.FT.

TOTAL: 652 SQ.FT.

UNITS: #611, 711

UNIT: #614

UNIT: #714

IN8

Illustrations are concept only. Plans and specifications are subject to change without notice. Actual floor space may vary from stated floor area. See sales representative for more information. E. & O. E.

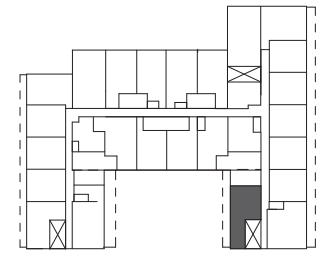

LEVEL 6

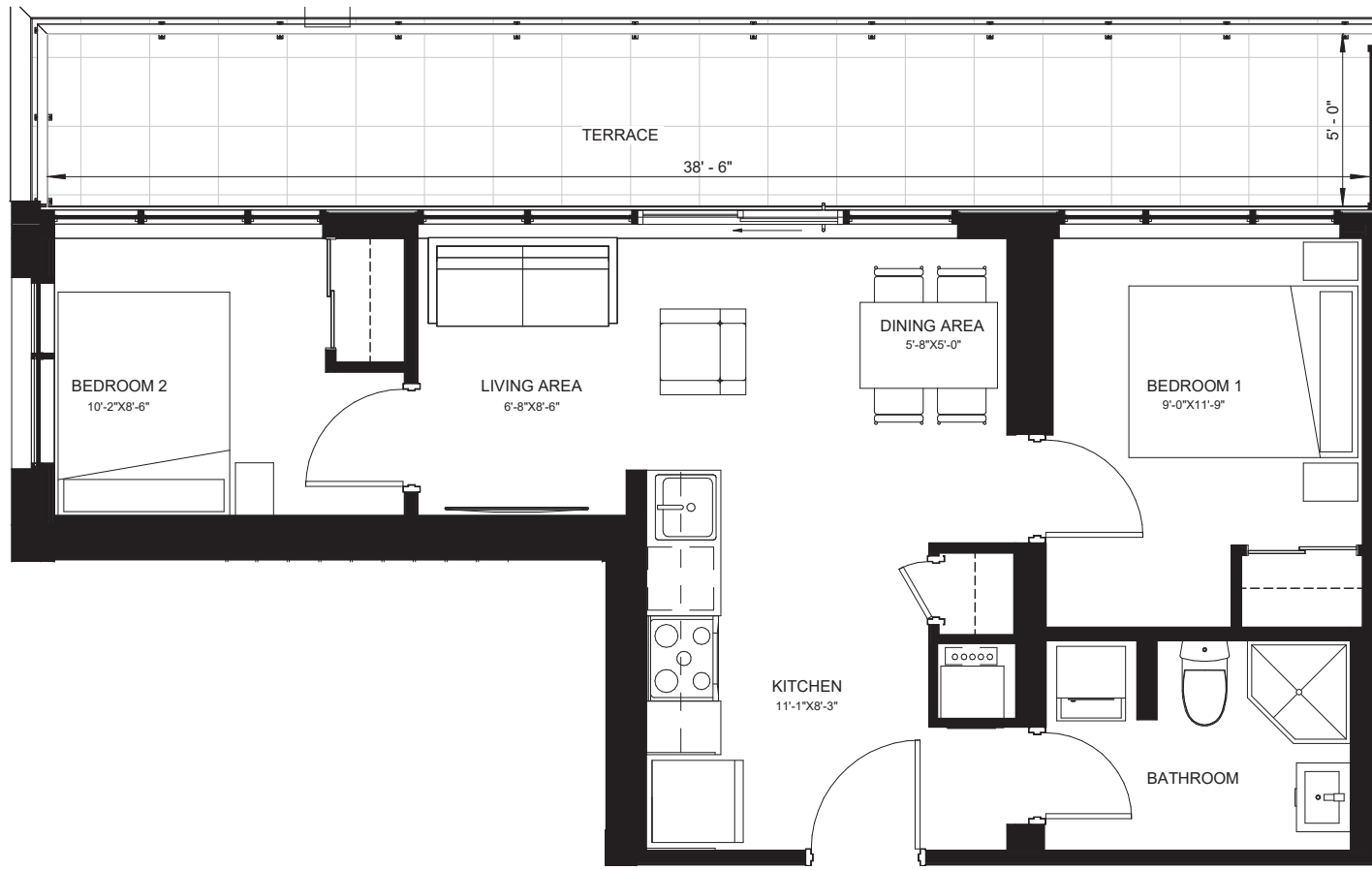

2 BED

E575t

SUITE: 575 SQ.FT. TERRACE: 218 SQ.FT. TOTAL: 793 SQ.FT. | UNIT: #623

IN8

**1107
MAIN**
HAMILTON

Illustrations are concept only. Plans and specifications are subject to change without notice. Actual floor space may vary from stated floor area. See sales representative for more information. E. & O. E.

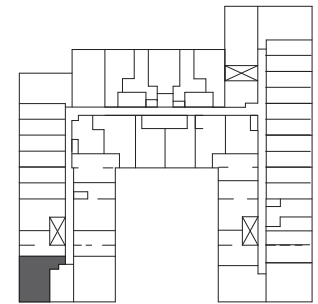
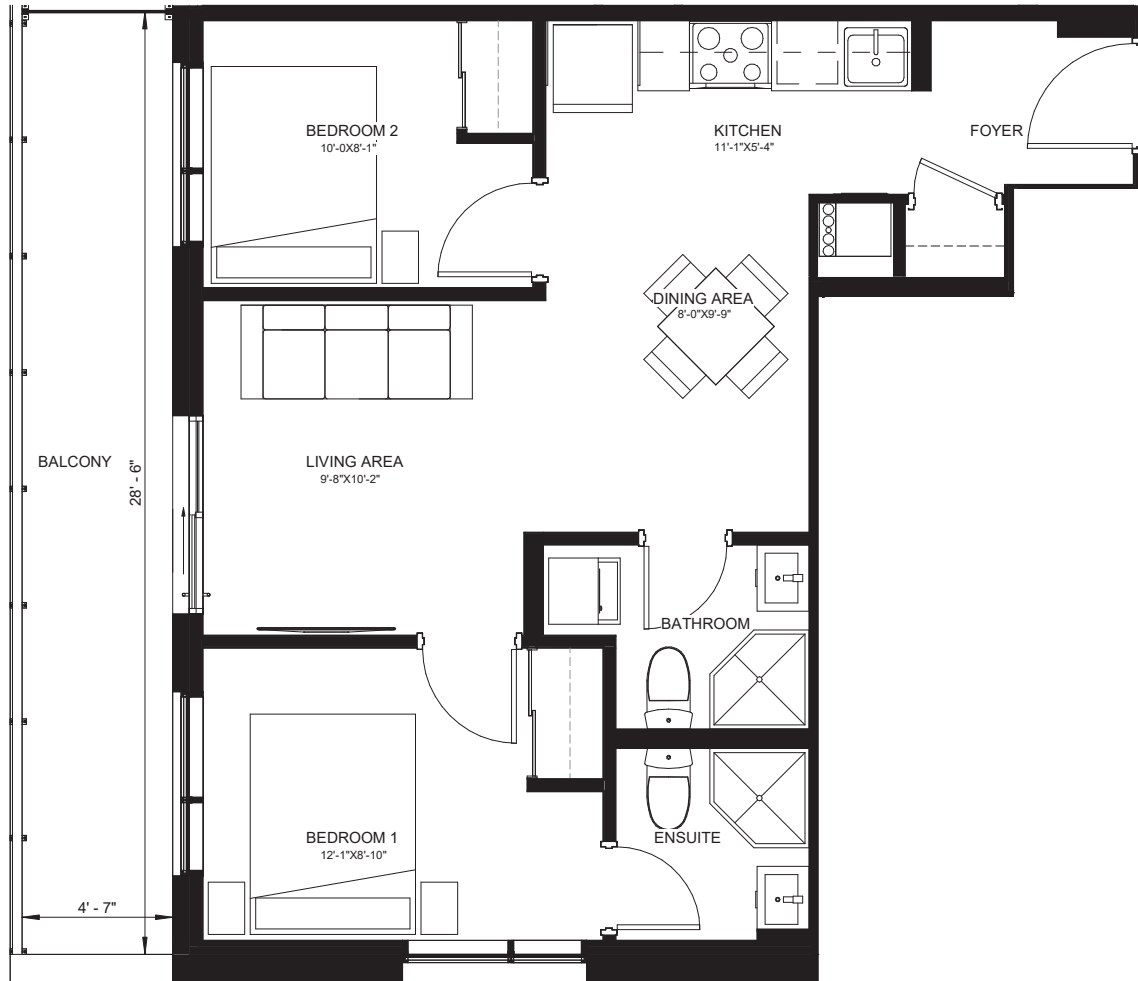

LEVEL 4

**1107
MAIN**
HAMILTON

2 BED

E643

SUITE: 643 SQ.FT. BALCONY: 144 SQ.FT. TOTAL: 787 SQ.FT. | UNIT: #408

IN8

Illustrations are concept only. Plans and specifications are subject to change without notice. Actual floor space may vary from stated floor area. See sales representative for more information. E. & O. E.

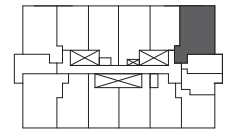
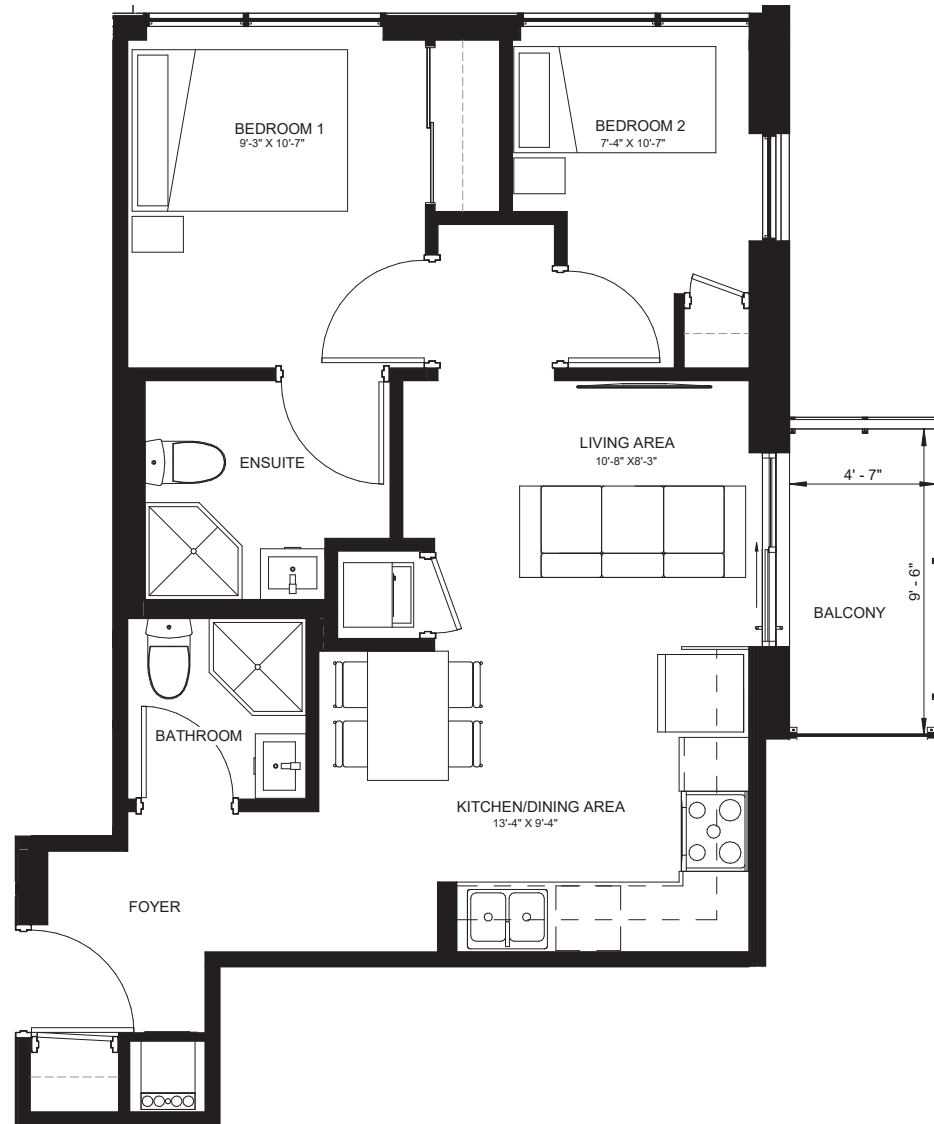

LEVELS 9-12

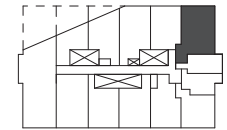

LEVEL 13

**1107
MAIN**
HAMILTON

2 BED

E648

SUITE: 648 SQ.FT. BALCONY: 48 SQ.FT. TOTAL: 696 SQ.FT. | UNIT: #910-1210, 1308

IN8

Illustrations are concept only. Plans and specifications are subject to change without notice. Actual floor space may vary from stated floor area. See sales representative for more information. E. & O. E.

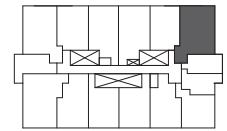
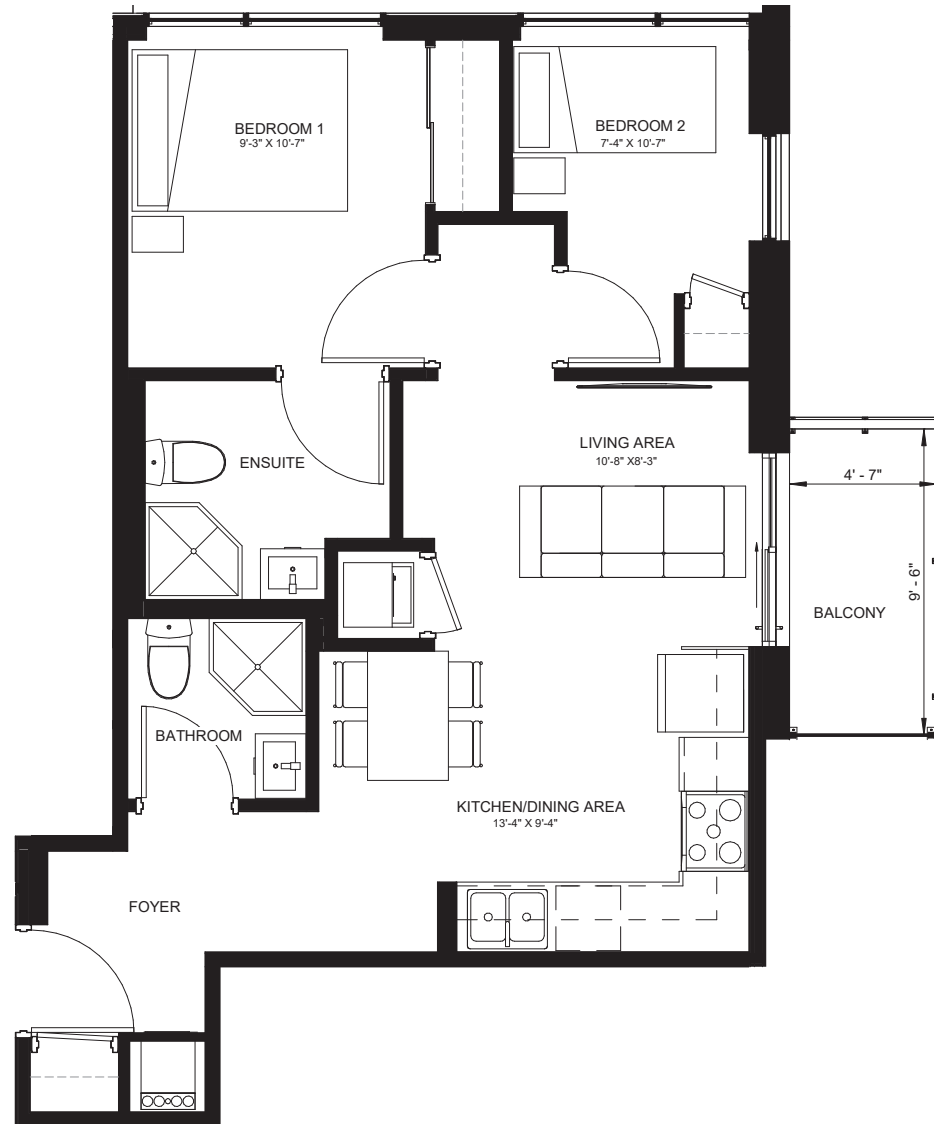

LEVELS 9-12

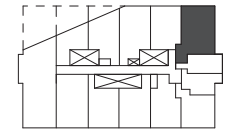

LEVEL 13

**1107
MAIN**
HAMILTON

2 BED

E648

SUITE: 648 SQ.FT. BALCONY: 48 SQ.FT. TOTAL: 696 SQ.FT. | UNIT: #910-1210, 1308

IN8

Illustrations are concept only. Plans and specifications are subject to change without notice. Actual floor space may vary from stated floor area. See sales representative for more information. E. & O. E.

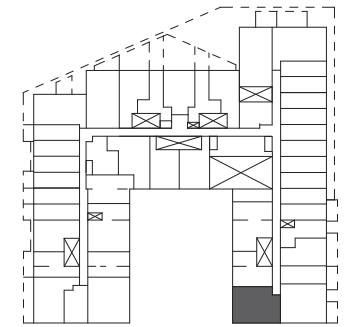
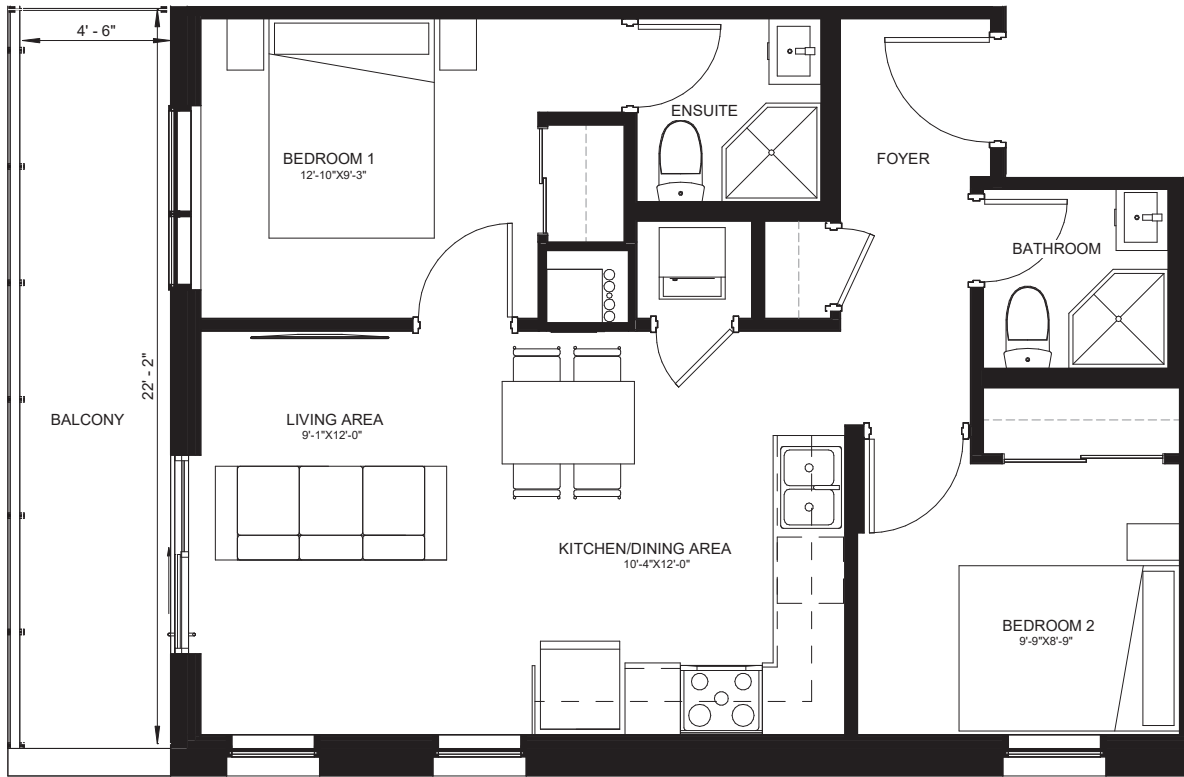

LEVEL 3

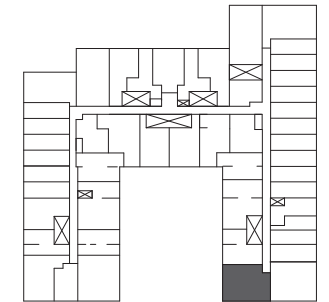

LEVEL 4

2 BED

E684

SUITE: 684 SQ.FT. TERRACE: 114 SQ.FT. TOTAL: 798 SQ.FT. | UNIT: #340
SUITE: 684 SQ.FT. BALCONY: 114 SQ.FT. TOTAL: 798 SQ.FT. | UNIT: #440

IN8

**1107
MAIN**
HAMILTON

Illustrations are concept only. Plans and specifications are subject to change without notice. Actual floor space may vary from stated floor area. See sales representative for more information. E. & O. E.

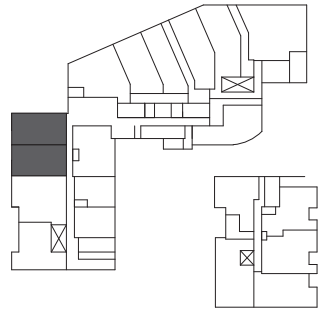

LEVEL 1

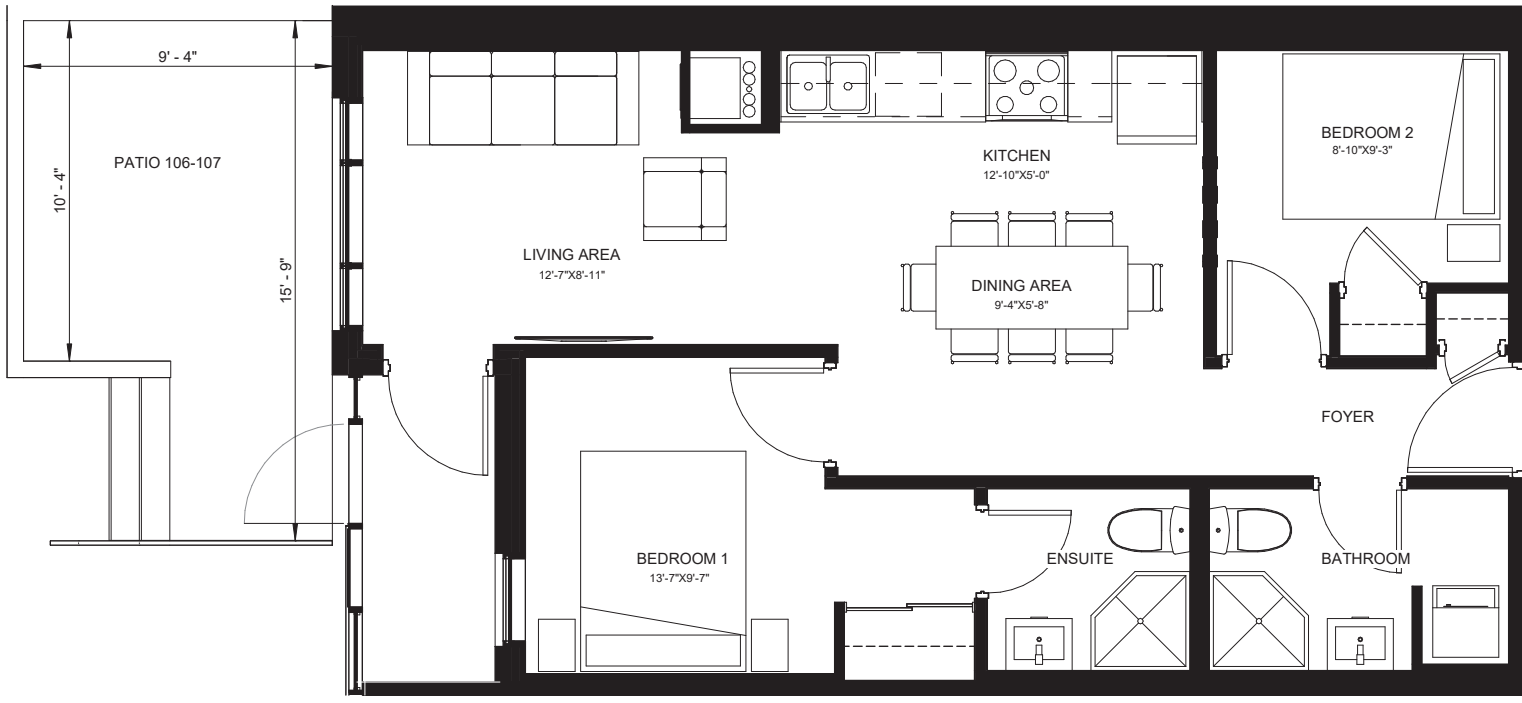

2 BED

E703

SUITE: 703 SQ.FT. PATIO: 111 SQ.FT. TOTAL: 814 SQ.FT. | UNIT: #107

SUITE: 682 SQ.FT. PATIO: 159 SQ.FT. TOTAL: 841 SQ.FT. | UNIT: #106

IN8

**1107
MAIN**
HAMILTON

Illustrations are concept only. Plans and specifications are subject to change without notice. Actual floor space may vary from stated floor area. See sales representative for more information. E. & O. E.

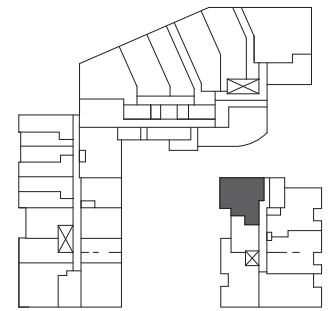
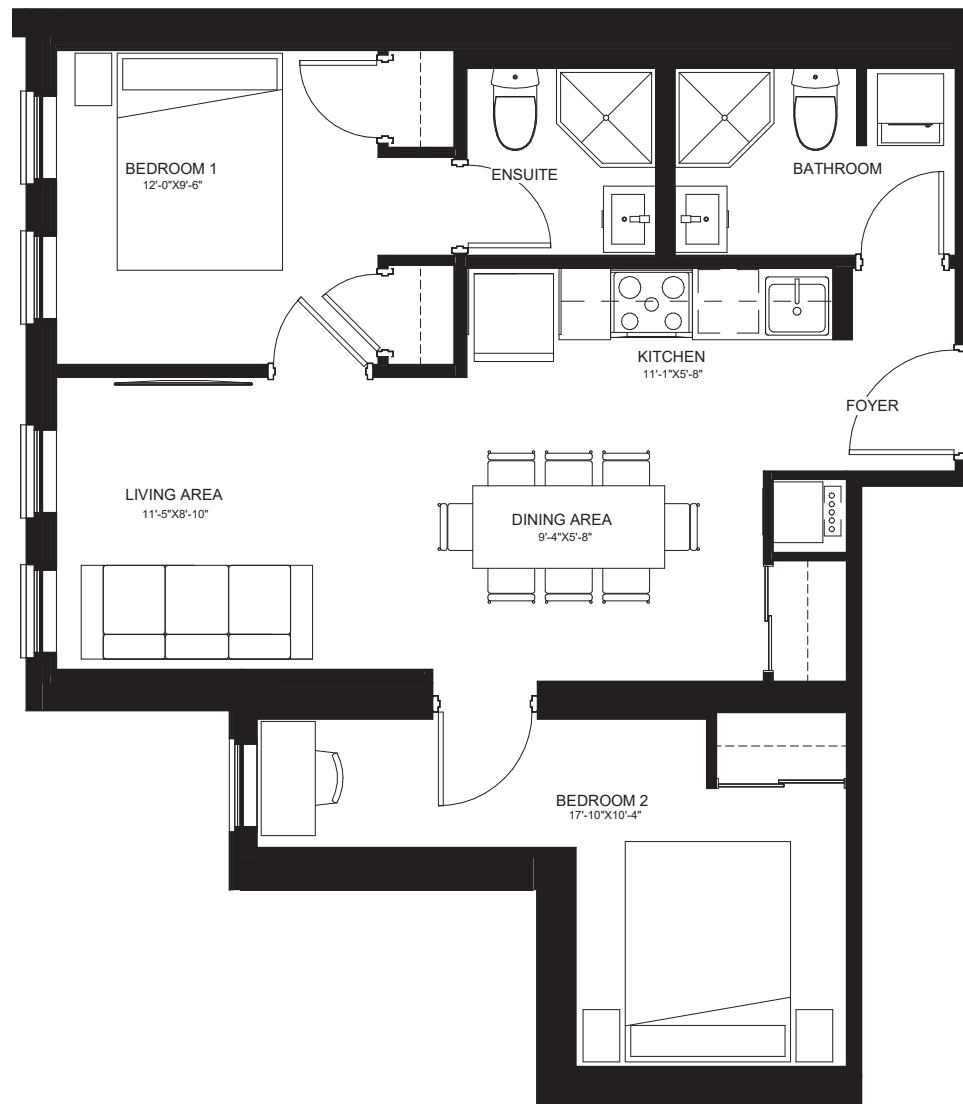

LEVEL 2

**1107
MAIN**
HAMILTON

2 BED

E732

SUITE: 732 SQ.FT. | UNIT: #219

IN8

Illustrations are concept only. Plans and specifications are subject to change without notice. Actual floor space may vary from stated floor area. See sales representative for more information. E. & O. E.

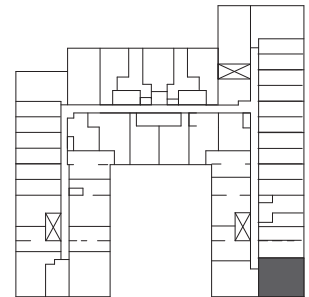

LEVEL 4



2 BED

E733

SUITE: 733 SQ.FT. BALCONY: 123 SQ.FT. TOTAL: 856 SQ.FT. | UNIT: #439

IN8

Illustrations are concept only. Plans and specifications are subject to change without notice. Actual floor space may vary from stated floor area. See sales representative for more information. E. & O. E.

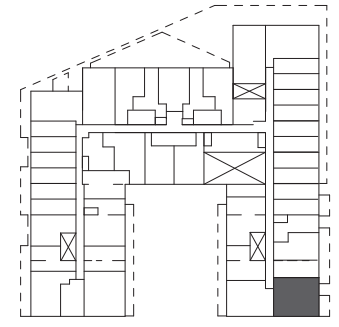
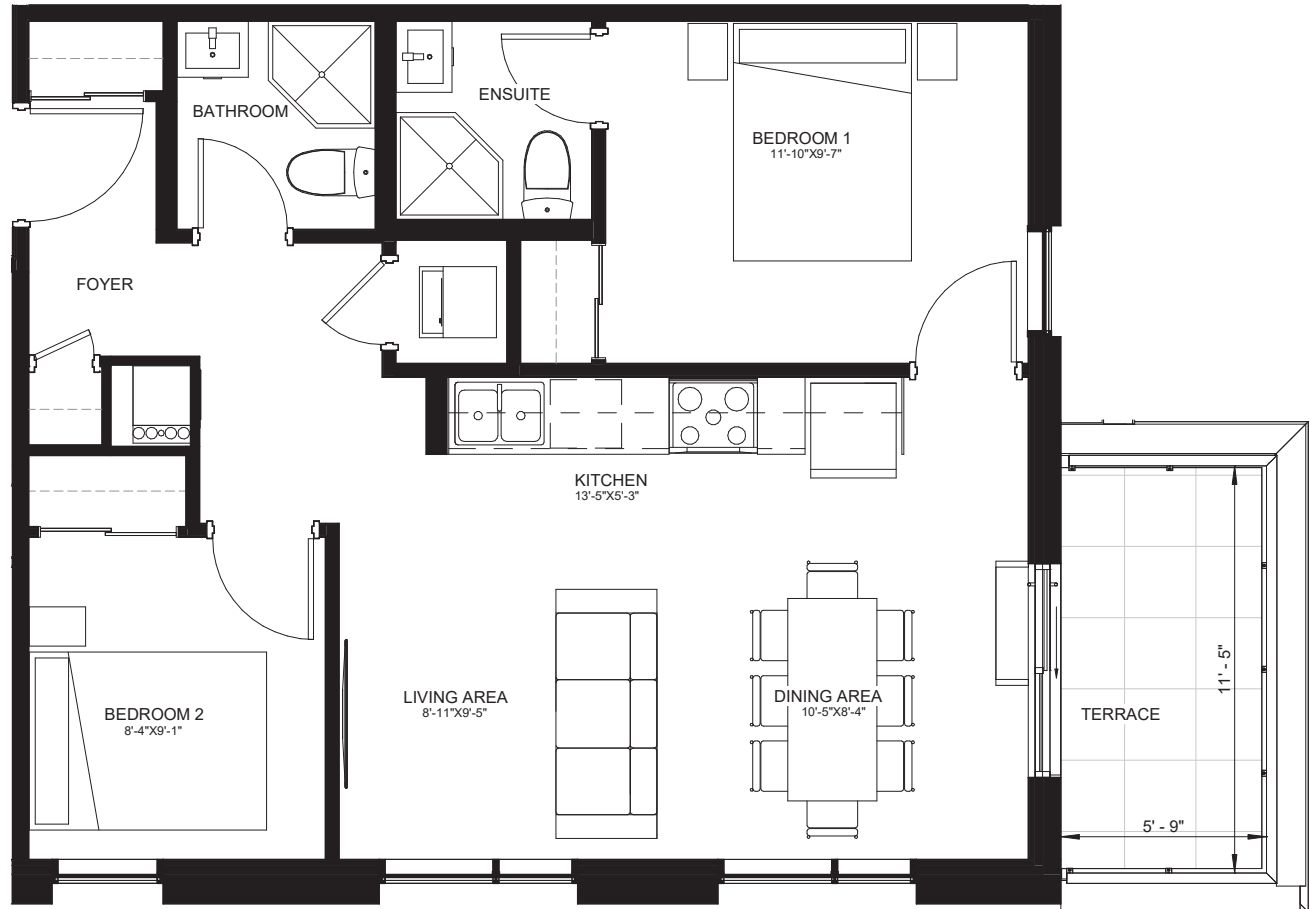

LEVEL 3

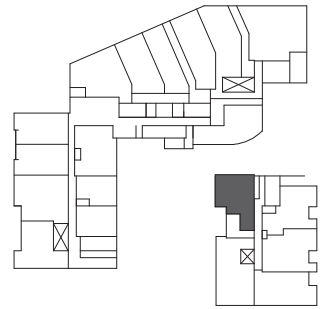

LEVEL 1

**1107
MAIN**
HAMILTON

2 BED

E777

SUITE: 777 SQ.FT. PATIO: 261 SQ.FT. TOTAL: 1038 SQ.FT. | UNIT: #112

IN8

Illustrations are concept only. Plans and specifications are subject to change without notice. Actual floor space may vary from stated floor area. See sales representative for more information. E. & O. E.